

# Needle Valves

## Double Block and Bleed

# 20DBNV Series

Pressures to 20,000 psi (1379 bar)

Parker Autoclave Engineers series DBNV double block and bleed valve is a three system manifold valve providing an economical and convenient method of blocking and bleeding in applications such as pressure monitoring and test, chemical injection and drain line isolation. The valve utilizes our standard valve packing and stem design to make it compact and easy to use. Manifold style valves reduce the number of fittings and space required for installation.

### Block and Bleed Features:

- 20DBNV Series valve design provides large valve performance in a small package.
- Tubing sizes: 1/4" to 1".
- Rising stem/barstock body design.
- Metal-to-metal seating achieves bubble-tight shut-off, longer stem/seat life in abrasive flow, greater durability for repeated on/off cycles and excellent corrosion resistance.
- PTFE encapsulated packing provides dependable stem and body sealing.
- Stem and packing gland design have been selected to achieve extended thread cycle life and reduced handle torque.
- Temperatures from -100°F (-73°C) to 600°F (316°C)

Parker Autoclave Engineers' valves are complemented by a complete line of fittings, tubings and accessories. The 20DBNV Series uses Parker Autoclave Engineers' pressure connections. This coned and threaded connection provides a reliable bubble-tight seal for dependable performance in gas or liquid service.



[www.autoclave.com](http://www.autoclave.com)

Needle Valves - 20DBNV Series  
Double Block and Bleed

# Needle Valves - 20DBNV Series

Pressures to 20,000 psi (1379 bar)

Tube Outside Diameter Size Inches	Connection Type	Orifice Size Inches (mm)	Rated $C_v$	Pressure Rating psi (bar) @ Room Temperature**
1/4	SF250CX	0.093 (2.36)	0.10	20,000 (1379)
3/8	SF375CX	0.093 (2.36)	0.27	20,000 (1379)
9/16	F562C	0.093 (2.36)	0.27	20,000 (1379)

*Notes:*

\*\* For complete temperature ratings see pressure/temperature rating guide in Technical Information section.

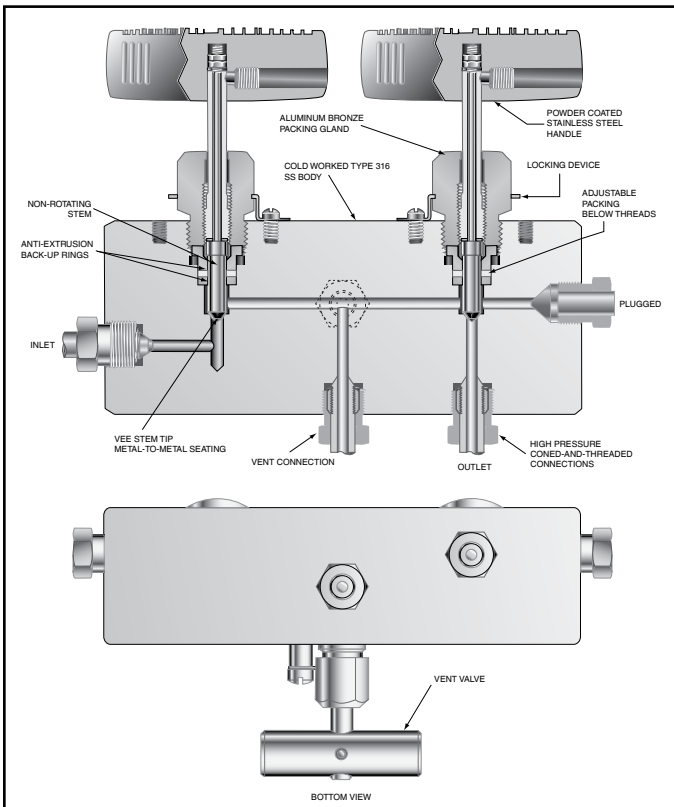

To ensure proper fit use Parker Autoclave Engineers tubing

## Valve Options

### Extreme Temperatures

Standard Parker Autoclave Engineers' valves with PTFE packing may be operated to 450°F (232°C). High temperature packing is available for service from 0°F (-17.8°C) to 800°F (427°C) by adding the following suffixes to catalog order number.

**TG** standard valve with PTFE glass packing to 600°F (316°C).

**B** standard valve with cryogenic trim material and PTFE packing to -100°F (-73°C).

*For additional valve options, contact your Sales Representative.*

*Note: Refer to the Tools, Installation, Operation and Maintenance section for proper maintenance procedures.*

## Ordering Procedure

For complete information on available end connections, see end connections options below. 20DBNV valves are furnished complete with tube connections.

Typical catalog number: **20DBNV M4 M4 XXX**

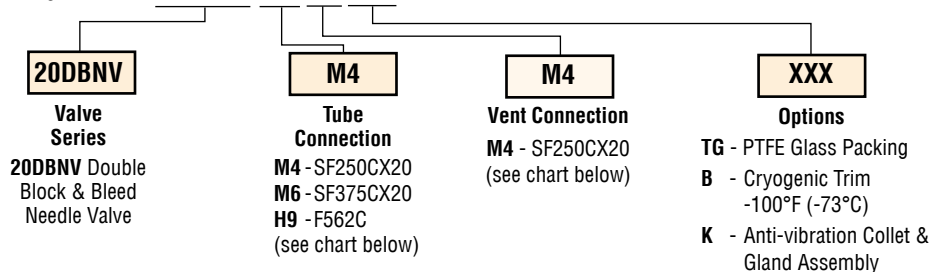

## Connection Options

Catalog Number	Tube Connection Number	Connection	MAWP @ Room Temperature	Vent Connection Number	Vent Connection
20DBNVM4M4	M4	SF250CX20	20,000 psi (1379 bar)	M4	SF250CX20
20DBNVM6M4	M6	SF375CX20	20,000 psi (1379 bar)	M4	SF250CX20
20DBNVH9M4	H9	F562C	20,000 psi (1379 bar)	M4	SF250CX20

MAWP: Maximum Allowable Working Pressure

## Valve Options

See needle valve options for complete information on available stem types, optional connections and additional valve options. For material options consult factory.

## Valve Maintenance

Consult your Parker Autoclave Engineers representative for pricing on repair kits. Refer to the Operation and Maintenance manual for proper maintenance procedures.

Catalog Number	Stem Type	Pipe Size	Orifice Dia.	Dimensions - inches (mm)															
				A	B	C	D	D <sub>1</sub>	E	F	G	H	M	N	O	P	Q	V	X

20DBNVM4M4	VEE	1/4	0.094	5.25	1.00	0.38	1.50	1.13	2.13	3.00	1.00	4.65	0.69	0.50	0.75	0.63	1.50	1.43	.50
		(6.35)	(2.39)	(133.35)	(25.40)	(9.65)	(38.10)	(28.70)	(54.10)	(76.20)	(25.40)	(118.11)	(17.53)	(12.70)	(19.05)	(16.00)	(38.10)	(36.32)	(12.70)
20DBNVM6M4	VEE	3/8	0.094	5.25	1.00	0.44	1.50	1.13	2.13	3.00	1.00	4.65	0.69	0.50	0.75	0.63	1.50	1.43	.50
		(9.53)	(2.39)	(133.35)	(25.40)	(11.18)	(38.10)	(28.70)	(54.10)	(76.20)	(25.40)	(118.11)	(17.53)	(12.70)	(19.05)	(16.00)	(38.10)	(36.32)	(12.70)
20DBNVH9M4	VEE	9/16	0.094	5.88	1.31	0.53	1.50	1.13	3.00	3.00	1.00	5.53	0.69	0.50	1.38	0.63	1.75	1.43	.75
		(14.29)	(2.39)	(149.35)	(33.27)	(13.46)	(38.10)	(28.70)	(76.20)	(76.20)	(25.40)	(140.46)	(17.53)	(12.70)	(35.05)	(16.00)	(44.45)	(36.32)	(19.05)

For complete information on available options, contact your Sales representative. 20DBNV Series valves are furnished with connection components unless otherwise specified.

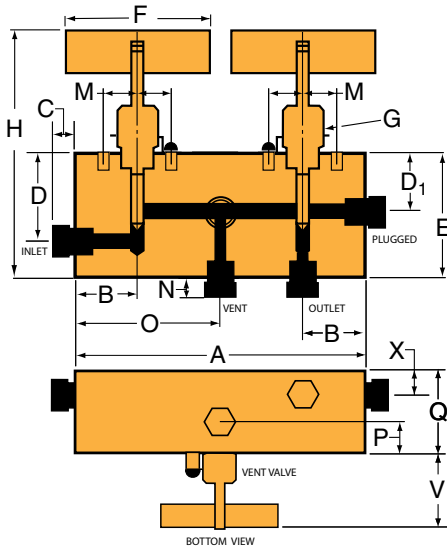

G - Packing gland mounting hole drill size  
H Dimension is with stem in closed position.  
All dimensions for reference only and subject to change

**For prompt service, Parker Autoclave Engineers stocks select products. Consult factory.**

**WARNING**

**FAILURE, IMPROPER SELECTION OR IMPROPER USE OF THE PRODUCTS AND/OR SYSTEMS DESCRIBED HEREIN OR RELATED ITEMS CAN CAUSE DEATH, PERSONAL INJURY AND PROPERTY DAMAGE.**

This document and other information from Parker Hannifin Corporation, its subsidiaries and authorized distributors provide product and/or system options for further investigation by users having technical expertise. It is important that you analyze all aspects of your application and review the information concerning the product or system in the current product catalog. Due to the variety of operating conditions and applications for these products or systems, the user, through its own analysis and testing, is solely responsible for making the final selection of the products and systems and assuring that all performance, safety and warning requirements of the application are met. The products described herein, including without limitation, product features, specifications, designs, availability and pricing, are subject to change by Parker Hannifin Corporation and its subsidiaries at any time without notice.

**Offer of Sale**

The items described in this document are available for sale by Parker Hannifin Corporation, its subsidiaries or its authorized distributors. Any sale contract entered by Parker will be governed by the provisions stated in Parker's standard terms and conditions of sale (copy available upon request).



**Instrumentation Products Division**  
Autoclave Engineers Operation  
8325 Hessinger Drive  
Erie, Pennsylvania 16509-4679 USA  
PH: 814-860-5700 FAX: 814-860-5811  
www.autoclave.com

Parker Hannifin Manufacturing Ltd.  
**Instrumentation Products Division, Europe**  
Industrial Estate Whitemill  
Wexford, Republic of Ireland  
PH: 353 53 914 1566  
FAX: 353 53 914 1582

**Caution!** Do not mix or interchange parts or tubing with those of other manufacturers. Doing so is unsafe and will void warranty.

**Caution!** Parker Autoclave Engineers Valves, Fittings and Tools are not designed to work with common commercial instrument tubing and will only work with tubing built to Parker Autoclave Engineers AES Specifications. Failure to do so will void warranty.