

Needle Valves

MicroMetering

VRMM Series

Pressures to 60,000 psi (4137 bar)

MicroMetering valves are designed for applications where more precise control of small flows is required than is possible with a standard regulating stem. Barrel and Thimble micrometer design permits settings to be repeated.

Metering is effected by a finely tapered stem acting in a precisely mated replaceable seat. Very fine stem position is achieved utilizing a 40 TPI thread. The Barrel and Thimble are set for proper metering at the factory.

These valves are designed for metering only and cannot be used as a shutoff valve. Minimum flow is factory set and occurs at "0" position. DO NOT OPERATE THE VALVE BELOW THE ZERO POSITION OR DAMAGE WILL RESULT. When shutoff action is required, a correlated shutoff valve from Parker AE series 10V, 30VM or 60VM should be installed in series with the MicroMetering valve.



MicroMetering Valve Features:

- Barrel and Thimble design permits repeatable settings.
- Barrel divisions every 0.025"
- 25 Thimble divisions, each representing 0.001" stem travel
- One revolution = 0.025" stem travel
- Cold-worked type 316 stainless steel body with stainless steel packing gland. Stem and seat are cold-worked type 316 stainless steel.
- Packing below stem threads is PTFE for the 10VRMM and 30VRMM valves and nylon-leather for the 60VRMM. For packing options, see Technical Information Section.
- SpeedBite "W" connections are used on the 10VRMM and Parker AE High Pressure coned-and-threaded connections on 30VRMM and 60VRMM.

Parker Autoclave Engineers valves are complemented by a complete line of fittings, tubing, check valves and line filters.



www.autoclave.com

Needle Valves - MicroMetering

Pressures to 60,000 psi (4137 bar)

	Tube Outside Diameter Size Inches	Connection Type	Orifice Size Inches (mm)	Rated C_v	Pressure Rating psi (bar) @ Room Temperature**
10VRMM	1/8	W125	0.062 (1.57)	0.004	15,000 (1034)
30VRMM	1/4	F250C	0.062 (1.57)	0.004	30,000 (2069)
60VRMM	1/4	F250C	0.062 (1.57)	0.004	60,000 (4137)
60VRMM	3/8	F375C	0.062 (1.57)	0.004	60,000 (4137)

Note:

** For complete temperature ratings see pressure/temperature rating guide in Technical Information section

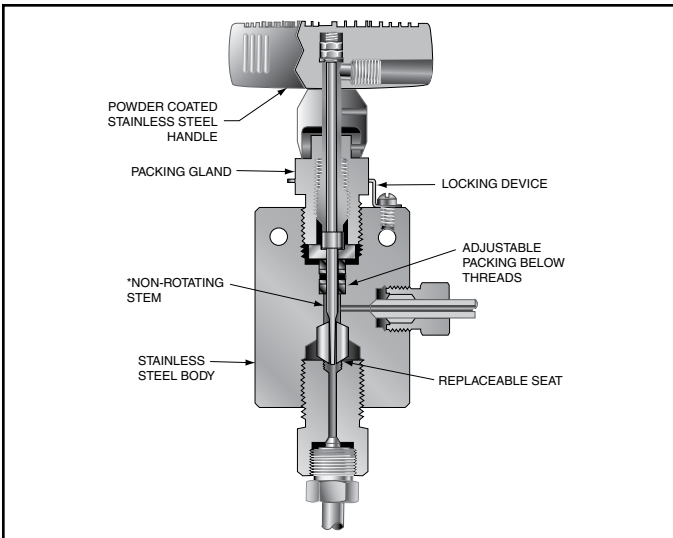

To ensure proper fit use Parker Autoclave Engineers tubing

Flow Coefficient (C_v)

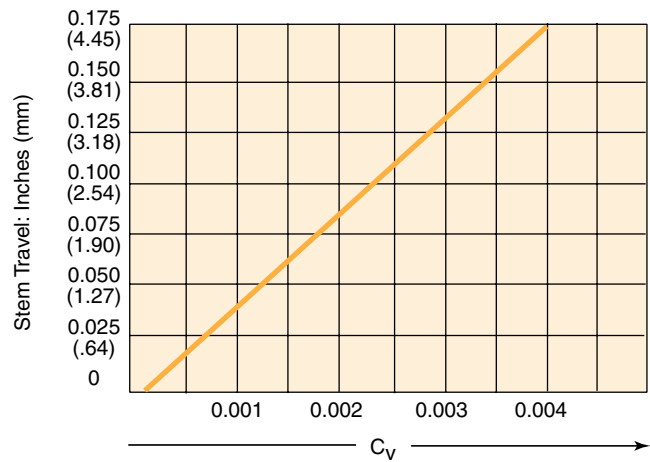

Ordering Procedure

For complete information on available stem types, optional connections and additional valve options, see Needle Valve Options section or contact your Sales Representative. VRMM Series valves are furnished complete with connection components, unless otherwise specified.

Typical catalog number: **60VRMM4812**

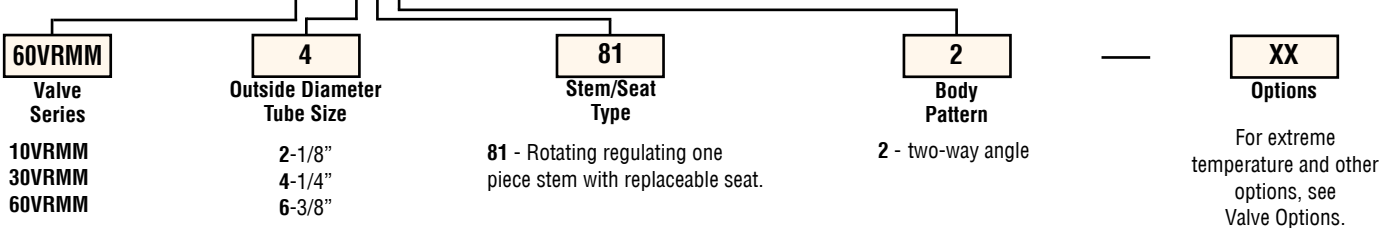

NOTE:

Ordering procedure for information only. Models available are shown in tables on next page.

Valve Options

Extreme Temperatures

Standard Parker Autoclave Engineers valves with PTFE packing may be operated to 450°F (232°C). High temperature packing and/or extended stuffing box is available for service from -423°F (-252°C) to 1200°F (649°C) by adding the following suffixes to catalog order number

TG - standard valve with PTFE glass packing to 600°F (316°C). **See note below.**

GY - standard valve with graphite braided yarn packing to 800°F (427°C).

HT - extended stuffing box valve with graphite braided yarn packing to 1200°F (649°C).

B - standard valve with cryogenic trim material and PTFE packing to -100°F (-73°C).

LT - extended stuffing box valve with PTFE packing & Cryogenic trim materials to -423°F (-252°C).

Note: 60VRMM valves supplied with Peak/PTFE Glass/Peek

Parker Autoclave Engineers does not recommend compression sleeve connections below 0°F (-17.8°C) or above 650°F (343°C). For additional valve options, contact your Sales Representative.

See Needle Valve options for stem and seat coatings for erosive service.

Valve Maintenance

Repair Kits: add "R" to the front of valve catalog number for proper repair kit.
(Example: **R60VRMM**)

Valve Bodies: Valve bodies are available. Order using the eight (8) digit part number found on the valve drawing or contact your Sales Representative for information.

Consult your Parker Autoclave Engineers representative for pricing on repair kits and valve bodies. Refer to the Tools, Installation, Operation and Maintenance section for proper maintenance procedures.

Catalog Number	Outside Diameter Tube	Orifice Diameter	Dimensions - inches (mm)											Block Thickness	Valve Pattern
			A	B	C	D	E	F	G	G ₁	H*	M	N		

10VRMM2812	1/8	0.062	1.50	0.88	0.31	0.94	1.56	3.00	0.62	0.16	5.06	1.00	0.25	0.75	See Figure 1
	(3.17)	(1.57)	(38.10)	(22.35)	(7.87)	(23.87)	(39.62)	(76.20)	(15.74)	(4.06)	(128.52)	(25.40)	(6.35)	(19.05)	
* Note: M dimension is distance between holes for mounting bracket.															

30VRMM4812	1/4	0.062	2.00	1.00	0.50	1.12	2.00	3.00	0.97	0.22	5.06	0.69	0.50	1.00	See Figure 2
	(6.35)	(1.57)	(50.80)	(25.40)	(12.70)	(28.44)	(50.80)	(76.20)	(24.63)	(5.58)	(128.52)	(17.25)	(12.70)	(25.40)	
60VRMM4812	1/4	0.062	2.00	1.00	0.50	1.31	2.63	3.00	0.97	0.22	6.06	0.69	0.38	1.00	
	(6.35)	(1.57)	(50.80)	(25.40)	(12.70)	(33.27)	(66.80)	(76.20)	(24.63)	(5.58)	(153.92)	(17.25)	(9.65)	(25.40)	
60VRMM6812	3/8	0.062	2.00	1.00	0.53	1.31	2.63	3.00	0.97	0.22	6.06	0.69	0.38	1.00	
	(9.53)	(1.57)	(50.80)	(25.40)	(13.46)	(33.27)	(66.80)	(76.20)	(24.63)	(5.58)	(153.92)	(17.25)	(9.65)	(25.40)	

G - Packing gland mounting hole drill size

G₁ - Bracket mounting hole size

Panel mounting drill size: 0.22" all valves.

* H Dimension is with stem in closed position.

All dimensions for reference only and subject to change.

For prompt service, Parker Autoclave Engineers stocks select products. Consult factory.

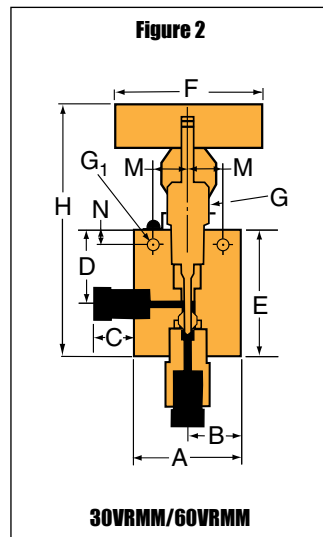
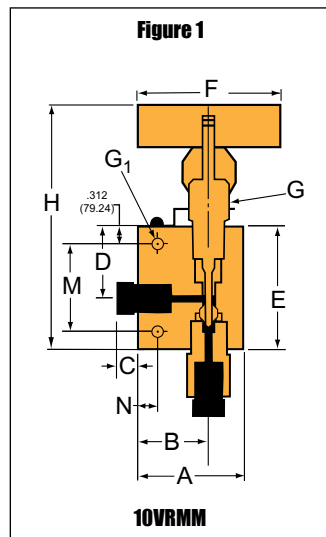

WARNING

FAILURE, IMPROPER SELECTION OR IMPROPER USE OF THE PRODUCTS AND/OR SYSTEMS DESCRIBED HEREIN OR RELATED ITEMS CAN CAUSE DEATH, PERSONAL INJURY AND PROPERTY DAMAGE.

This document and other information from Parker Hannifin Corporation, its subsidiaries and authorized distributors provide product and/or system options for further investigation by users having technical expertise. It is important that you analyze all aspects of your application and review the information concerning the product or system in the current product catalog. Due to the variety of operating conditions and applications for these products or systems, the user, through its own analysis and testing, is solely responsible for making the final selection of the products and systems and assuring that all performance, safety and warning requirements of the application are met. The products described herein, including without limitation, product features, specifications, designs, availability and pricing, are subject to change by Parker Hannifin Corporation and its subsidiaries at any time without notice.

Offer of Sale

The items described in this document are available for sale by Parker Hannifin Corporation, its subsidiaries or its authorized distributors. Any sale contract entered by Parker will be governed by the provisions stated in Parker's standard terms and conditions of sale (copy available upon request).



Instrumentation Products Division
Autoclave Engineers Operation
8325 Hessinger Drive
Erie, Pennsylvania 16509-4679 USA
PH: 814-860-5700 FAX: 814-860-5811
www.autoclave.com

Parker Hannifin Manufacturing Ltd.
Instrumentation Products Division, Europe
Industrial Estate Whitemill
Wexford, Republic of Ireland
PH: 353 53 914 1566
FAX: 353 53 914 1582

Caution! Do not mix or interchange parts or tubing with those of other manufacturers. Doing so is unsafe and will void warranty.

Caution! Parker Autoclave Engineers Valves, Fittings and Tools are not designed to work with common commercial instrument tubing and will only work with tubing built to Parker Autoclave Engineers AES Specifications. Failure to do so will void warranty.

ISO-9001 Certified