

# Pipes

## Seamless Pipes

Seamless pipes are in accordance with EEMUA-144, Section 1. They are manufactured from hot extruded shells followed by cold work and annealing.

## Welded Pipes

Longitudinally welded pipes are in accordance with EEMUA-144, Section 2. They are manufactured from hot rolled or cold rolled and annealed sheet or plates in accordance with BS 2870, BS 2875, ASTM B171 or ASTM B402. Mechanical testing is carried out in accordance with the standards above. The pipes are supplied in "as welded" condition.

## Dimensions

Dimensions are based on EEMUA -144, Tables 1.2.1-1.2.2 and 2.2.1-2.2.2. However, the pipe diameters range from ½ in./16 mm to 36 in./914 mm. Although the pipe dimensions of 38 in./965 mm and 40 in./1016 mm are not included in the EEMUA 144 - 1987 they are available on request as they are commonly specified. The corresponding wall thicknesses of the pipes comply with the pressure containment requirements of ASME B31.3 as well as the requirements of the International Association of Classification Societies. Pipes with other wall thicknesses are available on request.

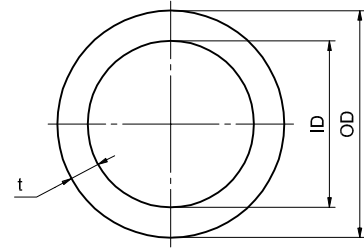

## Tolerances

See notes 1-4 for seamless and notes 2-4 for welded pipes.

## Weld Preparation

For wall thickness less than 3 mm, the pipes are supplied with plain weld ends. Larger thicknesses are supplied with the weld bevel of  $37 \frac{1}{2}^{\circ} \pm 2 \frac{1}{2}^{\circ}$ .



## Dimensions (mm)

### Seamless Pipe

Size		Specified Wall Thickness (mm) t		Theoretical Weight/Metre (kg)	
Nominal (in)	Specified (mm)	16 bar	20 bar	16 bar	20 bar
½	16	2.0	2.0	0.78	0.78
¾	25	2.0	2.0	1.29	1.29
1	30	2.5	2.5	1.93	1.93
1¼	38	2.5	2.5	2.49	2.49
1½	44.5	2.5	2.5	2.94	2.94
2	57	2.5	2.5	3.82	3.82
2½	76.1	2.5	2.5	5.15	5.15
3	88.9	2.5	2.5	6.05	6.05
4	108	3.0	3.0	8.82	8.82
6	159	3.0	3.5	13.10	15.24
8	219.1	4.0	4.5	24.10	27.04
10	267	4.5	5.5	33.10	40.27
12	323.9	5.5	7.0	49.05	62.10
14	368	6.5	8.0	65.80	80.64
16	419	7.0	9.0	80.75	103.32

### Seam-Welded Pipe

Size		Specified Wall Thickness (mm) t		Theoretical Weight/Metre (kg)	
Nominal (in)	Specified (mm)	16 bar	20 bar	16 bar	20 bar
16	419		9.0		103.32
18	457.2	8.0	9.5	100.62	119.10
20	508	8.5	11.0	118.90	153.10
24	610	10.5	13.0	176.30	217.30
28	711	12.0	15.0	234.90	292.21
32	813	13.5	17.0	302.20	378.76
36	914	15.5	19.0	390.00	475.97

#### Note 1

The pipe sizes up to including 4 in./108 mm are based on BS 2871: Part 2: Table 3 for outside diameters and their tolerances to allow for the use of capillary and compression fittings and brazed (and welded) slip-on flanges. The wall thickness of the 16 bar range have been increased to match the 20 bar range for mechanical strength.

#### Note 2

The pipe size 6 in./159 mm up to 16 in./419 mm are also based on BS 2871: Part 2: Table 3 for specified diameters but the tolerance have been applied to the inside diameters for facilitate alignment of matching weld preparations.

#### Note 3

The ovality of the finished pipe doesn't exceed 2% of the difference of the maximum and minimum diameter measured on the same cross section.

#### Note 4

Up to including 4 in./108 mm, the wall thickness doesn't vary by more than 10 % specified therein. For diameters from 6 in./159 mm and larger, the wall thickness is not less than 12.5 % of the specified value.

The pipes with other dimensions than mentioned herein are available on request. Please contact us for more information.

### Stock Dimensions

All seamless pipes are available from stock.

# Elbows

## Type and Construction

Elbows are in accordance with EEMUA-146, Section 1. Seamless elbows are typically available up to 18 inch/457 mm. Larger dimensions are manufactured from longitudinally welded half shells. 45° and 90° elbows are available in all sizes.

## Dimensions

Dimensions are based on EEMUA-146, Section 1, Figure 1.1, Tables 1.1-1.2 and 1.4-1.5., Standard elbows are supplied with long radius, i.e. 1.5 x O.D. Elbows with other dimensions are available on request.

## Tolerances

See Appendix C

## Weld Preparation

For wall thickness less than 3 mm, the elbows are supplied with plain weld ends. Larger thicknesses are supplied with the weld bevel of  $37\frac{1}{2}^\circ \pm 2\frac{1}{2}^\circ$ .

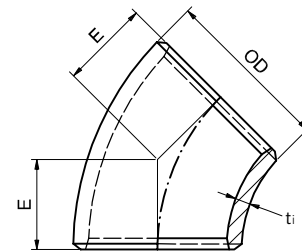
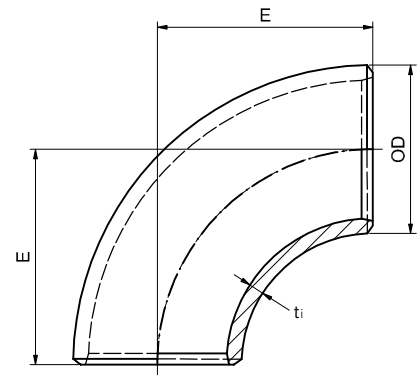

ti = intrados thickness (min) in accordance with EEMUA Publication No. 146: Section 1, Table 1.5

## Dimensions (mm)

Nominal Size	Specified Size (OD)	Specified Pipe Wall Thickness t		E-Centre to Face		Approx. Weight (kg)					
		16 bar	20 bar	45°	90°	45° 16 bar	45° 20 bar	90° 16 bar	90° 20 bar		
in	mm										
1	30	Use 20 bar	2.5	22	38	Use 20 bar	0.06	Use 20 bar	0.12		
1¼	38		2.5	25	43		0.09		0.13		
1½	44.5		2.5	29	57		0.15		0.30		
2	57		2.5	35	76		0.25		0.52		
2½	76.1		2.5	44	95		0.45		0.90		
3	88.9		2.5	51	114		0.65		1.25		
4	108		3.0	64	152		1.00		2.10		
6	159		3.0	95	229		2.30		2.70	4.70	5.50
8	219.1		4.0	127	305		6.00		6.50	12	13
10	267		4.5	159	381		10		12	20	24
12	323.9	5.5	190	457	17	23	35	45			
14	368	6.5	222	533	27	34	55	67			
16	419	7.0	254	610	38	50	77	99			
18	457.2	8.0	286	686	54	64	109	128			
20	508	8.5	318	762	71	92	142	184			
24	610	10.5	381	914	126	156	252	312			
28	711	12.0	438	1067	197	245	394	490			
32	813	13.5	502	1219	289	362	579	725			
36	914	15.5	565	1372	420	513	841	1026			

# Equal Tees

## Type and Construction

Tee pieces are in accordance with EEMUA-146, Section 1. Seamless tee pieces are typically available up to 8 in./219 mm; bigger dimensions are welded.

## Dimensions

Dimensions are based on EEMUA -146, Section 1, Figures 1.1-1.2, Tables 1.1-1.2 and 1.6. Tee pieces with other dimensions are available on request.

## Tolerances

See Appendix C

## Weld Preparation

For wall thickness less than 3 mm, the tees are supplied with plain weld ends. Larger thicknesses are supplied with the weld bevel of  $37\frac{1}{2}^{\circ} \pm 2\frac{1}{2}^{\circ}$ .

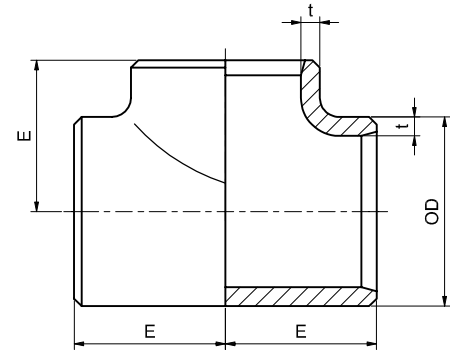

## Dimensions (mm)

Nominal Size		Specified Pipe Wall Thickness t		E	Approx. Weight (kg)		
in	mm	16 bar	20 bar		16 bar	20 bar	
1	30	Use 20 bar	2.5	38	Use 20 bar	0.30	
1¼	38		2.5	48		0.50	
1½	44.5		2.5	57		0.75	
2	57		2.5	64		1.00	
2½	76.1		2.5	76		1.60	
3	88.9		2.5	86		2.00	
4	108		3.0	105		3.25	
6	159		3.0	143		6.00	7.20
8	219.1		4.0	178		11.25	12.70
10	267		4.5	216		22.50	27.50
12	323.9	5.5	254	39.50	50.30		
14	368	6.5	279	62.00	76.00		
16	419	7.0	305	88.00	119.00		
18	457.2	8.0	343	128.00	152.00		
20	508	8.5	381	165.00	214.00		
24	610	10.5	432	266.00	330.00		
28	711	12.0	521	388.00	458.00		
32	813	13.5	597	508.00	606.00		
36	914	15.4	673	650.00	794.00		

# Reducing Tees

## Type and Construction

Pieces are in accordance with EEMUA -146, Section 1. Seamless tee pieces are typically available up to 8 in./219 mm; bigger dimensions are welded.

## Dimensions

Dimensions are based on EEMUA -146, Section 1, Figures 1.1-1.2, Tables 1.1-1.2 and 1.7.1-1.7.3. Tee pieces with other dimensions are available on request.

## Tolerances

See Appendix C

## Weld Preparation

For wall thickness less than 3 mm, the tees are supplied with plain weld ends. Larger thicknesses are supplied with the weld bevel of  $37\frac{1}{2}^{\circ} \pm 2\frac{1}{2}^{\circ}$ .

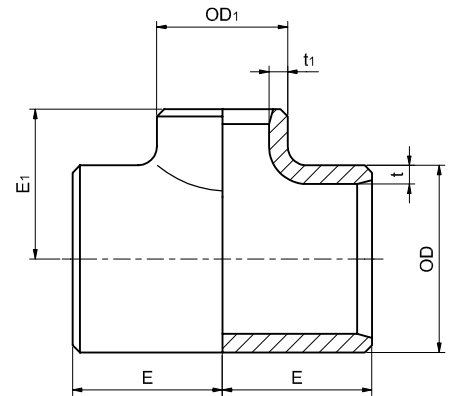

## Dimensions for 16 bar systems

Specified Size			Pipe Wall Thickness			Centre-to-End (mm)		Approx. Weight kg
OD mm	OD mm	OD <sub>1</sub> mm	t mm	t mm	t <sub>1</sub> mm	E nom	E <sub>1</sub> nom	
for sizes from 30 mm up to 108 mm use 20 bar								
		108			3.0		130	4.19
159	159	88.9	3.0	3.0	2.5	143	124	4.01
		76.1			2.5		121	3.96
		159			3.0		168	9.33
219.1	219.1	108	4.0	4.0	3.0	178	156	8.97
		88.9			2.5		152	8.82
		219.1			4.0		203	15.94
267	267	159	4.5	4.5	3.0	216	194	15.06
		108			3.0		184	14.71
		267			4.5		241	27.48
323.9	323.9	219.1	5.5	5.5	4.0	254	229	26.49
		159			3.0		219	25.62
		323.9			5.5		270	40.87
368	368	267	6.5	6.5	4.5	279	257	39.07
		219.1			4.0		248	38.20
		368			6.5		305	55.46
419	419	323.9	7.0	7.0	5.5	305	295	53.38
		267			4.5		283	51.62
		419			7.0		330	77.10
457.2	457.2	368	8.0	8.0	6.5	343	330	75.59
		323.9			5.5		321	73.45
		457.2			8.0		368	101.91
508	508	419	8.5	8.5	7.0	381	356	98.68
		368			6.5		356	97.16
		508			8.5		432	167.14
610	610	457.2	10.5	10.5	8.0	432	419	163.52
		419			7.0		406	160.21
		610			10.5		508	271.22
711	711	508	12.0	12.0	8.5	521	483	259.52
		457.2			8.0		470	255.88
		711			12.0		572	399.14
813	813	610	13.5	13.5	10.5	597	559	387.17
		508			8.5		533	375.34
		813			13.5		648	581.77
914	914	711	15.5	15.5	12.0	673	622	562.82
		610			10.5		610	551.05

# Reducing Tees

## Dimensions for 20 bar systems

Specified Size			Pipe Wall Thickness			Centre-to-End (mm)		Approx. Weight kg
OD mm	OD mm	OD <sub>1</sub> mm	t mm	t mm	t <sub>1</sub> mm	E nom	E <sub>1</sub> nom	
30	30	25	2.5	2.5	2.0	38	38	0.18
38	38	30	2.5	2.5	2.5	48	48	0.29
		25	2.5	2.5	2.0			0.28
		38	2.5	2.5	2.5			0.42
44.5	44.5	30	2.5	2.5	2.5	57	57	0.40
		25	2.5	2.5	2.0			0.38
		44.5					60	0.58
57	57	38	2.5	2.5	2.5	64	57	0.56
		30					51	0.53
		57					70	0.90
76.1	76.1	44.5	2.5	2.5	2.5	76	67	0.87
		38					64	0.85
		76.1					83	1.24
88.9	88.9	57	2.5	2.5	2.5	86	76	1.16
		44.5					73	1.12
		88.9					98	2.12
108	108	76.1	3.0	3.0	2.5	105	95	2.06
		57					89	1.98
		108			3.0		130	4.80
159	159	88.9	3.5	3.5	2.5	143	124	4.62
		76.1			2.5		121	4.57
		159			3.5		168	10.50
219.1	219.1	108	4.5	4.5	3.0	178	156	10.02
		88.9			2.5		152	9.87
		219.1			4.5		203	19.25
267	267	159	5.5	5.5	3.5	216	194	18.29
		108			3.0		184	17.82
		267			5.5		241	34.69
323.9	323.9	219.1	7.0	7.0	4.5	254	229	33.32
		159			3.5		219	32.38
		323.9			7.0		270	50.27
368	368	267	8.0	8.0	5.5	279	257	47.87
		219.1			4.5		248	46.66
		368			8.0		305	70.63
419	419	323.9	9.0	9.0	7.0	305	295	68.24
		267			5.5		283	65.89
		419			9.0		330	92.04
457.2	457.2	368	9.5	9.5	8.0	343	330	89.74
		323.9			7.0		321	87.31
		457.2			9.5		368	130.03
508	508	419	11.0	11.0	9.0	381	356	127.00
		368			8.0		356	124.69
		508			11.0		432	206.90
610	610	457.2	13.0	13.0	9.5	432	419	201.04
		419			9.0		406	197.91
		610			13.0		508	337.26
711	711	508	15.0	15.0	11.0	521	483	323.65
		457.2			9.5		470	317.78
		711			15.0		572	500.07
813	813	610	17.0	17.0	13.0	597	559	484.85
		508			11.0		533	471.09
		813			17.0		648	712.24
914	914	711	19.0	19.0	15.0	673	622	688.14
		610			13.0		610	673.17

# Caps

## Type and Construction

End caps are in accordance with EEMUA -146, Section 1 and seamless.

## Dimensions

Dimensions are based on EEMUA -146, Section 1, Figure 1.1, Tables 1.1-1.2 and 1.8. The additional wall compensatory thicknesses over and above the minimum pipe wall thicknesses are included. Caps with other dimensions are available on request.

## Tolerances

See Appendix C

## Weld Preparation

For wall thickness less than 3 mm, the caps are supplied with plain weld ends. Larger thicknesses are supplied with the weld bevel of  $37\frac{1}{2}^{\circ} \pm 2\frac{1}{2}^{\circ}$ .

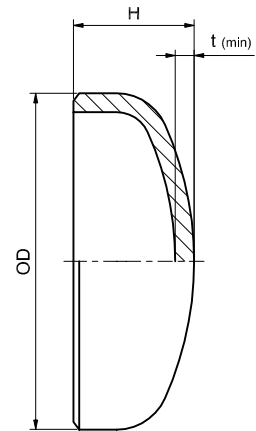

Specified Size OD	16 bar		20 bar		Approx. Weight	
	t min mm	H mm	t min mm	H mm	16 bar kg	20 bar kg
44.5	Use 20 bar	41	2.25	19.6	Use 20 bar	0.08
57			2.25	22.0		0.11
76.1			2.25	25.7		0.18
88.9			2.25	28.2		0.24
108			2.70	31.7		0.40
159	2.63	41	3.12	44	0.8	0.97
219.1	3.54	55	4.29	60	2.0	2.40
267	4.29	69	5.23	69	3.4	4.10
323.9	5.24	80	6.34	85	5.9	7.70
368	5.90	93	7.21	103	9.1	11.90
419	6.73	102	8.21	112	12.4	16.90
457.2	7.33	119	8.97	119	17.6	20.90
508	8.15	129	9.96	139	22.7	30.80
610	9.81	148	11.96	163	39.2	51.60
711	11.50	176	13.97	191	61.8	81.40
813	13.17	200	15.97	210	90.5	117.40
914	14.81	221	17.96	231	132.2	166.20

# Reducers

## Type and Construction

Eccentric and concentric reducers are in accordance with EEMUA -146, Section 1. The concentric reducers are typically supplied up to incl. 12 in./323.9 mm in seamless condition; bigger dimensions are seamwelded. The eccentric reducers are supplied up to incl. 8 in./219.1 mm in seamless condition; bigger dimensions are seamwelded.

## Dimensions

Dimensions are based on EEMUA -146, Section 1, Figures 1.1, Tables 1.1-1.2 and 1.9.1-1.9.3. Reducers with other dimensions are available on request.

## Tolerances

See Appendix C

## Weld Preparation

For wall thickness less than 3 mm, the reducers are supplied with plain weld ends. Larger thicknesses are supplied with the weld level of  $37 \frac{1}{2}^\circ \pm 2 \frac{1}{2}^\circ$ .

Specified Size OD mm	Length H mm	Specified Wall Thickness t x t <sub>1</sub>		Approx. Weight	
		16 bar mm	20 bar mm	16 bar kg	20 bar kg
57 x 30	76	2.5 x 2.5	2.5 x 2.5	0.29	0.29
57 x 38	76	2.5 x 2.5	2.5 x 2.5	0.29	0.29
57 x 44.5	76	2.5 x 2.5	2.5 x 2.5	0.29	0.29
76.1 x 57	89	2.5 x 2.5	2.5 x 2.5	0.40	0.40
88.9 x 57	89	2.5 x 2.5	2.5 x 2.5	0.44	0.44
88.9 x 76.1	89	2.5 x 2.5	2.5 x 2.5	0.50	0.50
108 x 57	102	3.0 x 2.5	3.0 x 2.5	0.67	0.67
108 x 76.1	102	3.0 x 2.5	3.0 x 2.5	0.75	0.75
108 x 88.9	102	3.0 x 2.5	3.0 x 2.5	0.80	0.80
159 x 57	140	3.0 x 2.5	3.5 x 2.5	1.32	1.54
159 x 76.1	140	3.0 x 2.5	3.5 x 2.5	1.44	1.68
159 x 88.9	140	3.0 x 2.5	3.5 x 2.5	1.52	1.77
159 x 108	140	3.0 x 3.0	3.5 x 3.0	1.64	1.91
219.1 x 76.1	152	4.0 x 2.5	4.5 x 2.5	2.49	2.79
219.1 x 88.9	152	4.0 x 2.5	4.5 x 2.5	2.60	2.92
219.1 x 108	152	4.0 x 3.0	4.5 x 3.0	2.77	3.11
219.1 x 159	152	4.0 x 3.0	4.5 x 3.5	3.21	3.60
267 x 108	178	4.5 x 3.0	5.5 x 3.0	4.84	5.89
267 x 159	178	4.5 x 3.0	5.5 x 3.5	5.52	6.71
267 x 219.1	178	4.5 x 4.0	5.5 x 4.5	6.31	7.68
323.9 x 159	203	5.5 x 3.0	7.0 x 3.5	7.63	9.65
323.9 x 219.1	203	5.5 x 4.0	7.0 x 4.5	8.60	10.89
323.9 x 267	203	5.5 x 4.5	7.0 x 5.5	9.38	11.87
368 x 219.1	330	6.5 x 4.0	8.0 x 4.5	17.24	21.50
368 x 267	330	6.5 x 4.5	8.0 x 5.5	18.68	23.00
368 x 323.9	330	6.5 x 5.5	8.0 x 7.0	20.39	25.00
419 x 267	356	7.0 x 4.5	9.0 x 5.5	23.44	30.00
419 x 323.9	356	7.0 x 5.5	9.0 x 7.0	25.43	32.50
419 x 368	356	7.0 x 6.5	9.0 x 8.0	26.97	34.50
457.2 x 323.9	381	8.0 x 5.5	9.5 x 7.0	30.70	37.03
457.2 x 368	381	8.0 x 6.5	9.5 x 8.0	34.06	41.50
457.2 x 419	381	8.0 x 7.0	9.5 x 9.0	37.90	46.50
508 x 368	508	8.5 x 6.5	11.0 x 8.0	50.80	64.10
508 x 419	508	8.5 x 7.0	11.0 x 9.0	55.40	71.10
508 x 457.2	508	8.5 x 8.0	11.0 x 9.5	61.20	75.70
610 x 419	508	10.5 x 7.0	13.0 x 9.0	70.00	87.50
610 x 457.2	508	10.5 x 8.0	13.0 x 9.5	76.30	92.50
610 x 508	508	10.5 x 8.5	13.0 x 11.0	81.80	102.80
711 x 457.2	610	12.0 x 8.0	15 x 9.5	109.30	133.60
711 x 508	610	12.0 x 8.5	15 x 11.0	116.30	146.70
711 x 610	610	12.0 x 10.5	15 x 13.0	137.30	170.10
813 x 508	610	13.5 x 8.5	17 x 11	136.40	172.60
813 x 610	610	13.5 x 10.5	17 x 13	158.40	197.30
813 x 711	610	13.5 x 12.0	17 x 15	179.50	224.20
914 x 610	610	15.5 x 10.5	19 x 13	185.00	226.70
914 x 711	610	15.5 x 12	19 x 15	207.10	255.00
914 x 813	610	15.5 x 13.5	19 x 17	231.30	285.80

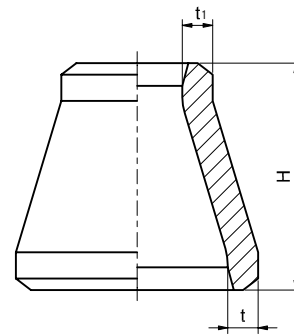
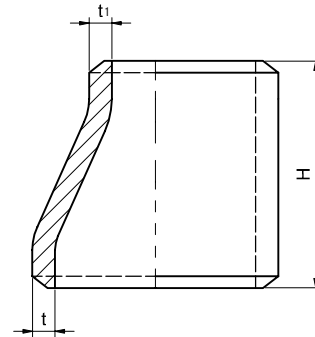



# Saddle Pieces

## Type and Construction

Saddle pieces are in accordance with EEMUA -146, Section 7. Saddle pieces up to including 12 in./323.9 mm are supplied in seamless. Larger dimensions are manufactured from seamless or welded pipes as well as plates.

## Dimensions

Dimensions are based on EEMUA -146, Section 7, Figures 7.1-7.3 and Tables 7.1.1-7.3.2. Saddle pieces with other dimensions are available on request.

## Tolerances

The tolerances are based on EEMUA - 146, Section 7, Tables 7.2.1-7.3.2.

## Weld Preparation

Welding ends of butt weld ends for wall thickness less than 3 mm, the saddle pieces are supplied with plain weld ends. Larger thicknesses are supplied with the weld bevel of  $37\frac{1}{2}^{\circ} \pm 2\frac{1}{2}^{\circ}$ .

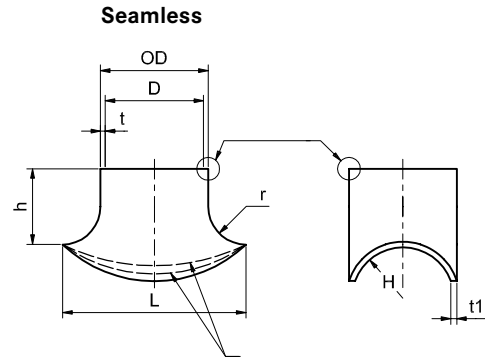

## Seamless saddle pieces

Header Specified OD mm	Branch Size Range mm	t		Dimension L mm	Tolerance on L mm	Dimension h mm	Tolerance on h mm	r mm
		16 bar mm	20 bar mm					
All header sizes equal to or larger than branch up to and including 914 x 15.5 (16 bar) 610 x 13 (20 bar)	<b>323</b>	5.5	7.0	560	± 6	185	± 2.5	100
	<b>267</b>	4.5	5.5	447	± 5	155	± 2.5	90
	<b>219.1</b>	4.0	4.5	379	± 5	125	± 1.6	80
	<b>159</b>	3.0	3.5	279	± 4	95	± 1.6	60
	<b>108</b>	3.0	3.0	188	± 4	75	± 1.6	40
	<b>88.9</b>	2.5	2.5	149	± 3	55	± 1.6	30
	<b>76.1</b>	2.5	2.5	126	± 3	50	± 1.6	25
	<b>57</b>	2.5	2.5	97	± 3	40	± 1.6	20
	<b>44.5</b>	2.5	2.5	74	± 3	35	± 1.6	15
<b>38</b>	2.5	2.5	64	± 3	35	± 1.6	13	

## Note

Other sizes and reducing saddles are available on request.

# Saddle Pieces

## Type and Construction

Saddle pieces are in accordance with EEMUA -146, Section 7. Saddle pieces up to including 12 in./323.9 mm are supplied in seamless. Larger dimensions are manufactured from seamless or welded pipes as well as plates.

## Dimensions

Dimensions are based on EEMUA -146, Section 7, Figures 7.1-7.3 and Tables 7.1.1-7.3.2. Saddle pieces with other dimensions are available on request.

## Tolerances

The tolerances are based on EEMUA - 146, Section 7, Tables 7.2.1-7.3.2.

## Weld Preparation

Welding ends of butt weld ends for wall thickness less than 3 mm, the saddle pieces are supplied with plain weld ends. Larger thicknesses are supplied with the weld bevel of  $37\frac{1}{2}^{\circ} \pm 2\frac{1}{2}^{\circ}$ .

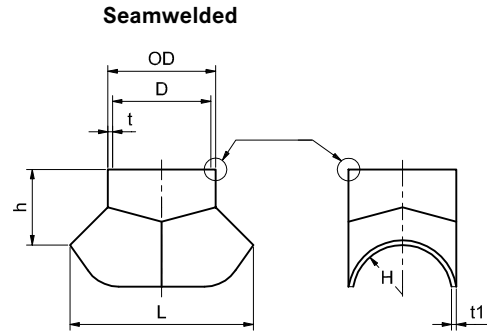

### Seamwelded saddle pieces - 16 bar rating

Header Specified OD mm	Branch Size Range mm	Dimension	Tolerance on	Dimension	Tolerance on
		L mm	L mm	h mm	h mm
All header sizes equal to or larger than 323.9 x 5.5 up to and including 914 x 15.5	<b>914 x 15.5</b>	1550	± 7	460	± 3.5
	<b>813 x 13.5</b>	1400	± 7	410	± 3.5
	<b>711 x 12</b>	1225	± 7	360	± 3.5
	<b>610 x 10.5</b>	1020	± 7	300	± 3.0
	<b>508 x 8.5</b>	880	± 6	275	± 3.0
	<b>457.2 x 8.0</b>	800	± 6	250	± 3.0
	<b>419 x 7.0</b>	680	± 6	225	± 3.0
	<b>368 x 6.5</b>	613	± 6	200	± 3.0
	<b>323.9 x 5.5</b>	560	± 6	185	± 2.5
	<b>267 x 4.5</b>	447	± 5	155	± 2.5
<b>219.1 x 4.0</b>	379	± 5	125	± 1.6	

### Seamwelded saddle pieces - 20 bar rating

Header Specified OD mm	Branch Size Range mm	Dimension	Tolerance on	Dimension	Tolerance on
		L mm	L mm	h mm	h mm
All header sizes equal to or larger than 323.9 x 7.0 up to and including 610 x 13	<b>610 x 13</b>	1020	± 7	300	± 3.0
	<b>508 x 11</b>	880	± 7	275	± 3.0
	<b>457.2 x 9.5</b>	800	± 6	250	± 3.0
	<b>419 x 9.0</b>	680	± 6	225	± 3.0
	<b>368 x 8.0</b>	613	± 6	200	± 3.0
	<b>323.9 x 7.0</b>	560	± 6	185	± 2.5
	<b>267 x 5.5</b>	447	± 5	155	± 2.5
<b>219.1 x 4.5</b>	379	± 5	125	± 1.6	

# Weldolets

## Type and Construction

Weldolets are in accordance with EEMUA-146, Section 6. The components are manufactured by hot forging and machining from extruded bars (solid or hollow).

## Dimensions

The dimensions and tolerances are suitable for welding to seamless and seam-welded pipes to EEMUA - 144. The branch size covered is from ½ in./ 16 mm to 16 in./419 mm. Other branch sizes are available on request. The weldolets covered are suitable for application to header sizes from ½ in./16 mm to 38 in./965 mm. The sizes of the header pipes for a given branch size are consolidated in accordance with MSS SP-97, Section 3.3 and Figure 1, whereas the gap distance between the header pipe radius and the fitting inlet radius doesn't exceed 1/16 in./1.6 mm.

The design of the self reinforced connection is in accordance with ASME B31.3 Section 304.3 suitable for both 16 and 20 bar pressure ratings. The additional design feature is the smooth entry into the connection to reduce the turbulences.

The overall dimensions are based on EEMUA -146, Section 6, Table 6.1.

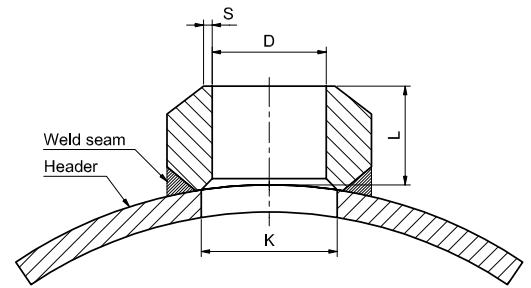

## Weldolets

Branch Specified OD mm	Header Size Range mm	L Nom mm	D mm	K Nom mm	S min/max mm
16	16 - 965	18	11.57 - 12.45	12.8 - 17.0	1.8 - 2.0
25	25 - 965	23	20.58 - 21.45	26.0 - 26.0	1.8 - 2.0
30	30 - 965	26	24.48 - 25.56	31.0 - 31.0	2.25 - 2.5
38	38 - 965	29	32.49 - 33.57	34.8 - 40.0	2.25 - 2.5
44.5	44.5 - 965	32	38.99 - 40.07	41.3 - 45.0	2.25 - 2.5
57	57 - 965	36	51.62 - 52.70	53.8 - 58.0	2.25 - 2.5
76.1	76.1 - 965	43	70.65 - 71.80	72.9 - 75.0	2.25 - 2.5
88.9	88.9 - 965	44 - 53	83.50 - 84.65	85.7 - 88.0	2.25 - 2.5
108	108 - 965	53	101.40 - 102.85	104.8 - 108.0	0.8 - 2.4
133	159 - 965	56	125.50 - 127.00	146.0	0.8 - 2.4
159	159 - 965	60	151.50 - 153.00	155.8 - 170.0	0.8 - 2.4
219.1	219.1 - 965	70	209.40 - 210.90	215.9 - 219.0	0.8 - 2.4
267	267 - 965	78	255.20 - 256.70	263.8 - 267.0	0.8 - 2.4
323.9	323.9 - 965	86	309.00 - 310.50	320.7 - 324.0	0.8 - 2.4
368	368 - 965	89	350.00 - 352.00	364.8 - 368.0	0.8 - 2.4
419	419 - 965	94	399.00 - 401.00	415.0 - 419.0	0.8 - 2.4

# Composite Weld Neck Flanges: Weld Neck Stub Ends and Backing Flanges

## Type and Construction

The weld neck stub ends are in accordance with EEMUA 145, Section 1A for 16 and 20 bar systems. The range of sizes covered is ½ in./16 mm to 36 in./914 mm. Other sizes are available on request. The stub ends are subdivided in two types short (Type S) based on DIN 86037 and long (Type L) based on MSS SP-43 suit the appropriate pipe dimension. The Type L stub ends are included to facilitate the attachments of this type of flange to butt weld welding fittings in accordance with EEMUA-146.

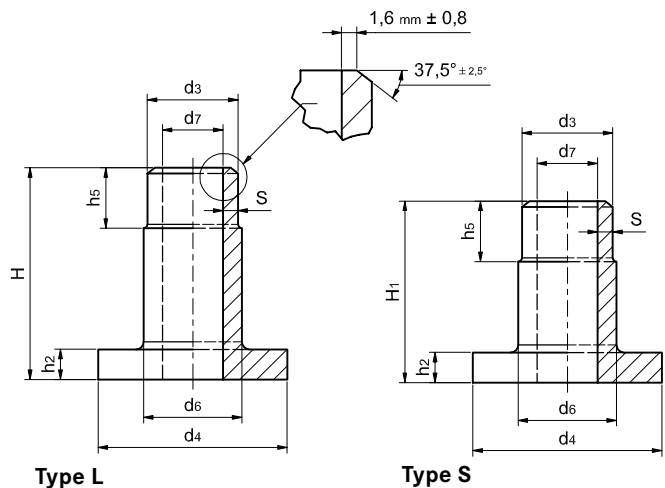

Weld preparation applicable to  $S_1 \geq 3,0$  mm

## Dimensions

Dimensions are based on EEMUA-145, Section 1A, Tables 1.2-1.3.

## Tolerances

The tolerances are based on EEMUA-145, Section 1A, Table 1.5.1.

## Weld Preparation

The stub ends with  $S_1 < 3$  mm are supplied with plain weld ends. Larger dimension are supplied with the weld bevel of  $37 \frac{1}{2}^\circ \pm 2 \frac{1}{2}^\circ$ .

Nominal Size		16 bar					20 bar		Type S		Type L		16 bar		20 bar	
		$d_3$	$d_4$	$d_6$	$d_7$	$d_7$	$H_1$	H	$h_2$	$h_5$	S	S	min.	min.		
in	mm	mm	mm	mm	mm	mm	mm	mm	mm	mm	mm	mm	mm	mm		
½	16	16	40	18	Use 20 bar	12.00	35	51	4	15	Use 20 bar		2.0			
¾	25	25	50	27		21.00	40	51	5	15		2.0				
1	30	30	60	32		25.00	40	51	5	15		2.5				
1¼	38	38	70	40		33.03	40	51	5	15		2.5				
1½	44.5	44.5	80	46.5		39.53	45	51	6	15		2.5				
2	57	57	99	59		52.16	45	64	6	15		2.5				
2½	76.1	76.1	120	78		71.23	45	64	6	15		2.5				
3	88.9	88.9	130	91		84.08	50	64	7	15		2.5				
4	108	108	158	110		102.13	50	76	7	15		3.0				
6	159	159	212	161.5		153.75	152.38	50	89	9		15	3.0	3.5		
8	219.1	219.1	270	222	211.10	210.10	50	102	9	15	4.0	4.5				
10	267	267	320	270	257.97	255.93	50	127	9	15	4.5	5.5				
12	323.9	323.9	370	327	312.83	309.74	50	152	11	16	5.5	7.0				
14	368	368	430	371	354.22	351.00	50	152	11	16	6.5	8.0				
16	419	419	482	422	404.17	399.84	50	152	12	16	7.0	9.0				
18	457.2	457.2	530	460	441.50	438.50	50	152	12	16	8.0	9.5				
20	508	508	585	511	490.50	486.50	50	152	12	20	8.5	11.0				
24	610	610	685	613	589.50	584.50	60	152	14	20	10.5	13.0				
28	711	711	800	719	687.50	681.50	60	190	19	24	12.0	15.0				
32	813	813	905	821	786.50	779.50	60	190	20.5	24	13.5	17.0				
36	914	914	1000	922	883.50	876.50	60	190	22	32	15.5	19.0				

# Composite Weld Neck Flanges: Weld Neck Stub Ends and Backing Flanges

## Type and Construction

The weld neck backing flanges are in accordance with EEMUA 145, Section 1B and are suitable for both 16 and 20 bar pressure rating. The range of sizes covered is ½ in./16 mm to 36 in./914 mm Class 150. Other sizes are available on request. Drilling and outside diameter dimensions of flange sizes ½ in./16 mm-24 in./610 mm are in accordance with ANSI B16.5 and BS 1560, whereas the larger sizes, 28 in./711 mm -36 in./914 mm are in accordance with MSS SP-44.

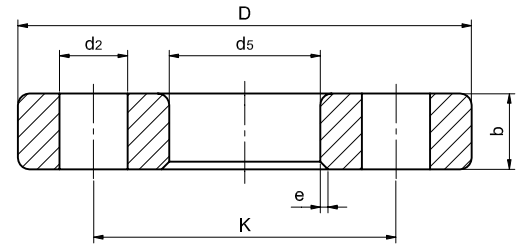

The backing flanges are manufactured from forged carbon steel in accordance with ASTM A105. The chemical composition and mechanical properties of the components are in accordance with EEMUA 145, Section 1B, Table 1.6.2. The recommended bolting is in accordance with ASTM A193-B7. Unless otherwise specified the flanges are protected by hot dipped galvanising. Additional organic coatings such as polyamide epoxy are available on request.

## Dimensions

Dimensions are based on EEMUA -145, Section 1B, Table 1.4.

## Tolerances

The tolerances are based on EEMUA - 145, Section 1B, Table 1.5.2.

Nominal Size		b		D	min.	d <sub>2</sub>		d <sub>5</sub>	K	No. of Bolts	e	Approx. Total Weight incl. Stub End – kg			
in	mm	mm	mm			in	mm					mm	mm	S	16 bar
½	16	89	14	5/8	15.9	19	60.3	4	2	As for 20 bar	0.64	0.66			
¾	25	98	14	5/8	15.9	28	69.8	4	3		0.8	0.9			
1	30	108	14	5/8	15.9	33	79.4	4	3		1.0	1.0			
1¼	38	117	14	5/8	15.9	41	88.9	4	3		1.2	1.3			
1½	44.5	127	14	5/8	15.9	48	98.4	4	3		1.5	1.6			
2	57	152	18	¾	19.0	62	120.6	4	3		2.5	2.6			
2½	76.1	178	18	¾	19.0	81	139.7	4	3		3.3	3.4			
3	88.9	190	19	¾	19.0	94	152.4	4	3		3.8	3.9			
4	108	229	24	¾	19.0	113	190.5	8	3		6.6	6.9			
6	159	279	27	7/8	22.2	164	241.3	8	4		9.7	10.4	9.9	10.7	
8	219.1	343	31	7/8	22.2	225	298.4	8	5	15.0	16.7	15.1	17.0		
10	267	406	38	1	25.4	273	362.0	12	5	23.1	26.6	23.5	27.5		
12	323.9	483	41	1	25.4	330	431.8	12	7	34.6	41.0	35.2	43.1		
14	368	533	45	1 1/8	28.6	374	476.2	12	7	44.7	53.4	45.5	55.8		
16	419	597	51	1 1/8	28.6	426	539.8	16	7	60.0	70.5	60.6	72.5		
18	457.2	635	52	1 ¼	31.8	465	577.8	16	7	66.0	78.0	68.0	84.3		
20	508	698	58	1 ¼	31.8	517	635.0	20	7	84.4	98.7	86.0	103.5		
24	610	813	71	1 3/8	34.9	618	749.3	20	9	131.4	149.8	134.0	156.5		
28	711	927	81	1 3/8	34.9	727	864.0	28	9	180.3	202.9	183.6	212.1		
32	813	1060	95	1 5/8	41.1	829	978.0	28	9	269.0	296.8	275.5	311.2		
36	914	1168	105	1 5/8	41.1	931	1086.0	32	9	335.8	369.8	341.0	385.8		

# Composite Slip-On Flanges: Slip-On Stub Ends and Slip-On Backing Flanges

## Type and Construction

The slip-on stub ends are in accordance with EEMUA 145, Section 2A and are suitable for 16 and 20 pressure rating. The range of sizes covered is ½ in./16 mm to 4 in./108 mm Class 150. The slip-on backing flanges are in accordance with EEMUA 145, Section 2B. Drilling and outside diameter dimensions are in accordance with ANSI B16.5 and BS 1560. The backing flanges are suitable for use in both 16 and 20 bar systems. The backing flanges are manufactured from forged carbon steel in accordance with ASTM A105. The chemical composition and mechanical properties of the components are in accordance with EEMUA 145, Section 2B, Table 2.5.2. The recommended bolting is in accordance with ASTM A193-B7. Unless otherwise specified the flanges are protected by hot dipped galvanising. Additional organic coatings such as polyamide epoxy are available on request.

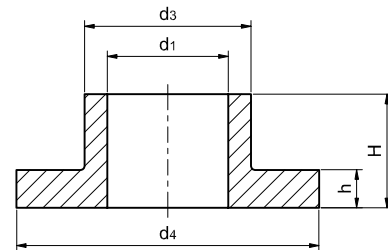
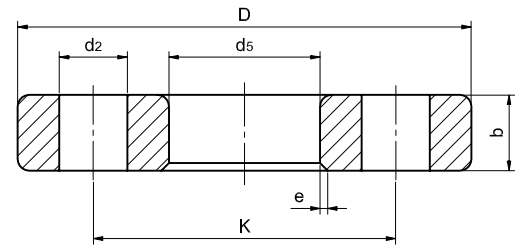

## Dimensions

Dimensions are based on EEMUA -145, Section 2A and 2B, Tables 2.2 and 2.3.

## Tolerances

The tolerances are based on EEMUA - 145, Section 2A and 2B, Tables 2.4.1 and 2.4.2.

Nominal Size		Inner Stub End Dimension					Outer Steel Flange - Dimension						No. of Bolt Holes	Approx. Total Weight (kg)
in	mm	d <sub>1</sub> mm	d <sub>3</sub> mm	d <sub>4</sub> mm	H mm	h mm	D mm	b mm	K mm	d <sub>5</sub> mm	d <sub>2</sub> in/mm	e mm		
½	16	16.07	21	40	16	5	89	14	60.3	23	5/8 /15.9	3	4	0.61
¾	25	25.08	31	53	16	5	98	14	69.8	33	5/8 /15.9	3	4	0.75
1	30	30.08	36	60	18	5	108	14	79.4	38	5/8 /15.9	3	4	0.92
1¼	38	38.10	45	70	18	5	117	14	88.9	47	5/8 /15.9	3	4	1.10
1½	44.5	44.60	51	80	19	5	127	14	98.4	53	5/8 /15.9	3	4	1.30
2	57	57.23	67	99	19	6	152	18	120.6	69	¾ /19	3	4	2.20
2½	76.1	76.33	87	120	19	6	178	18	139.7	89	¾ /19	3	4	3.00
3	88.9	89.18	100	130	21	7	190	19	152.4	103	¾ /19	3	4	3.50
4	108	108.38	120	158	23	7	229	24	190.5	123	¾ /19	3	4	6.00

# Solid Weld Neck Flanges

## Type and Construction

The solid weld neck flanges are in accordance with EEMUA 145, Section 3 for 16 and 20 bar systems. The range of sizes covered is ½ in./16 mm to 36 in./914 mm Class 150. Other sizes are available on request. Drilling and outside diameter dimensions of flange sizes ½ in./16 mm-24 in./610 mm are in accordance with ANSI B16.5 and BS 1560, whereas the larger sizes, 28 in./711 mm -36 in./914 mm are in accordance with MSS SP-44. The recommended bolting is in accordance with ASTM B150 alloy UNS C63000.

## Dimensions

Dimensions are based on EEMUA -145, Section 3, Table 3.2-3.3.

## Tolerances

The tolerances are based on EEMUA - 145, Section 3, Table 3.4.

Nominal Size		Outside Diameter of Flange	Thickn. of Flange	Diameter of Hub	Hub Dia at weld Chamfer	Length Through Hub	16 bar Bore of Flange	20 bar Bore of Flange	
in	mm	D mm	b mm	d <sub>6</sub> mm	d <sub>3</sub> mm	H mm	d <sub>7</sub> mm	d <sub>7</sub> mm	
½	<b>16</b>	89	14	23	16	48	Use 20 bar	12.00	
¾	<b>25</b>	98	16	32	25	52		21.00	
1	<b>30</b>	108	16	42	30	56		25.00	
1¼	<b>38</b>	117	17	51	38	57		33.03	
1½	<b>44.5</b>	127	20	61	44.5	62		39.53	
2	<b>57</b>	152	25	73	57	64		52.16	
2½	<b>76.1</b>	178	27	91	76.1	70		71.23	
3	<b>88.9</b>	190	27	105	88.9	70		84.08	
4	<b>108</b>	229	27	135	108	76		102.13	
6	<b>159</b>	279	27	192	159	89		153.75	152.38
8	<b>219.1</b>	343	31	246	219.1	98		211.10	210.10
10	<b>267</b>	406	31	305	267	98		257.97	255.93
12	<b>323.9</b>	483	35	365	323.9	98		312.83	309.74
14	<b>368</b>	533	41	400	368	99		354.22	351.00
16	<b>419</b>	597	43	457	419	106	404.17	399.84	
18	<b>457.2</b>	635	45	505	457.2	113	441.50	438.50	
20	<b>508</b>	698	45	559	508	118	490.50	486.50	
24	<b>610</b>	813	49	664	610	137	589.50	584.50	
28	<b>711</b>	927	72	748	711	145	687.50	681.40	
32	<b>813</b>	1060	72	876	813	160	786.50	779.50	
36	<b>914</b>	1168	72	984	914	175	883.50	876.50	

It should be noted that although these flanges are flat faced, inside bolt circle gaskets shall be used and special care should be taken to avoid overtightening the bolting.

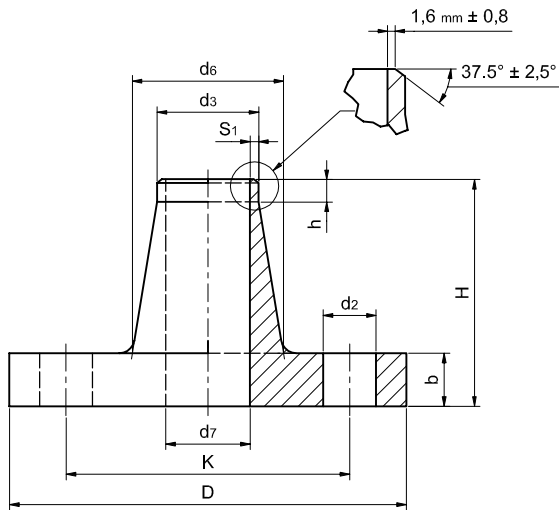

Weld preparation applicable to  $S_1 \geq 3,0 \text{ mm}$



16 bar Thickn. of Hub at Welding End $S_1$ min mm	20 bar Thickn. of Hub at Welding End $S_1$ min mm	16 bar Approx. Weight kg	20 bar Approx. Weight kg	Parallel Length of Hub h mm	Diameter of Bolt Circle K mm	Drilling No. of Bolts	Diameter of Bolt Holes $d_2$ mm
Use 20 bar	2.0	Use 20 bar	0.72	8	60.3	4	15.9
	2.0		1.04	7	69.8	4	15.9
	2.5		1.3	8	79.4	4	15.9
	2.5		1.7	8	88.9	4	15.9
	2.5		2.3	7	98.4	4	15.9
	2.5		4.1	9	120.6	4	19.0
	2.5		6.1	8	139.7	4	19.0
	2.5		7.1	8	152.4	4	19.0
	3.0		10.2	8	190.5	8	19.0
	3.0		15.5	15.8	8	241.3	8
4.0	4.5	27.7	28.0	8	298.4	8	22.2
4.5	5.5	38.5	39.3	8	362.0	12	25.4
5.5	7.0	61.6	62.9	8	431.8	12	25.4
6.5	8.0	86.8	88.4	8	476.2	12	28.6
7.0	9.0	114.2	115.6	8	539.8	16	28.6
8.0	9.5	136.0	140.7	8	577.8	16	31.8
8.5	11.0	164.6	168.4	8	635.0	20	31.8
10.5	13.0	247.7	253.7	8	749.3	20	34.9
12.0	15.0	453.0	461.1	8	864.0	28	34.9
13.5	17.0	599.0	611.1	8	978.0	28	41.1
15.5	19.0	741.0	755.7	8	1086.0	32	41.1



# Solid Slip-On Flanges

## Type and Construction

The solid slip-on flanges are in accordance with EEMUA 145, Section 4 and are suitable for both 16 and 20 bar systems. The range of sizes covered is ½ in./16 mm to 4 in./108 mm Class 150. Drilling and outside diameter dimensions are in accordance with ANSI B16.5 and BS 1560. The recommended bolting is in accordance with ASTM B150 alloy UNS C63000.

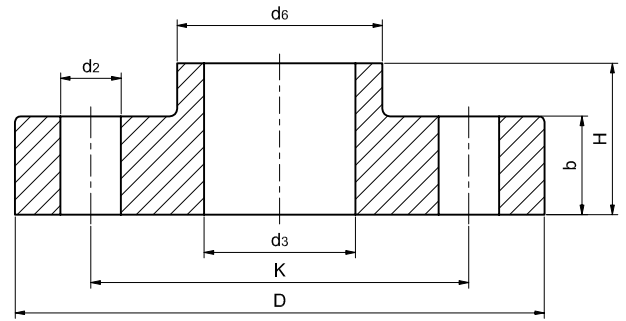

## Dimensions

Dimensions are based on EEMUA -145, Section 4, Table 4.2.

## Tolerances

The tolerances are based on EEMUA - 145, Section 4, Table 4.3.

Nominal Size		Flange Diameter	Flange Thickness	H	D <sub>6</sub>	No. of Bolt Holes	Diameter of Bolt Holes	K	Approx. Weight
in	mm	D	b	H	d <sub>6</sub>		d <sub>2</sub>	K	kg
½	16	89	14	20	23	4	15.9	60.3	0.66
¾	25	98	16	24	32	4	15.9	69.8	0.91
1	30	108	16	24	47	4	15.9	79.4	1.16
1¼	38	117	17	26	51	4	15.9	88.9	1.4
1½	44.5	127	20	26	61	4	15.9	98.4	1.9
2	57	152	25	28	73	4	19.0	120.6	3.3
2½	76.1	178	27	32	91	4	19.0	139.7	4.7
3	88.9	190	27	34	105	4	19.0	152.4	5.2
4	108	229	27	40	135	8	19.0	190.5	7.7

# Composite Blind Flanges

## Type and Construction

The composite blind flanges are in accordance with manufacturer's specification. The range of sizes covered is ½ in./16 mm to 36 in./914 mm Class 150. Drilling and outside diameter dimensions of flange sizes ½ in./16 mm-24 in./610 mm are in accordance with ANSI B16.5 and BS 1560, whereas the larger sizes, 28 in./711 mm -36 in./914 mm are in accordance with MSS SP-44. The blind flanges are suitable for use both 16 and 20 bar systems.

The composite blind flanges are manufactured from forged carbon steel in accordance with ASTM A105 clad with copper nickel disk. In contrast to raised face blind flanges in accordance to ANSI B16.5, the supplied composite flanges are considered as flat face, since the diameter of the copper nickel disk  $d_1$  is equivalent to the flange diameter  $d_4$  weld neck stub end in accordance with EEMUA 145, Section 1A. By these means, uniform contact over the weld neck stub end faces is ensured. The recommended bolting is in accordance with ASTM A193-B7.

Unless otherwise specified the flanges are protected by hot dipped galvanising. Additional organic coatings such as polyamide epoxy are available on request. Solid blind flanges are available on request.

## Tolerances

Tolerances are equivalent to the dimensions for weld neck backing flanges based on EEMUA - 145, Section 1B, Table 1.5.2.

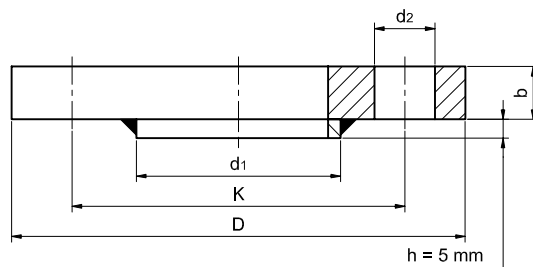

Nom. Size in	Spec. Size mm	Flange Diameter D mm	Diameter of Bolt Holes $d_2$		Flange Thickness b min mm	Diameter of Disk $d_1$ mm	No. of Bolt Holes	Approx. Total Weight (kg)
			K mm	in				
½	16	89	60.3	5/8	14	40	4	0.82
¾	25	98	69.8	5/8	14	50	4	1.04
1	30	108	79.4	5/8	14	50	4	1.31
1¼	38	117	88.9	5/8	14	70	4	1.58
1½	44.5	127	98.4	5/8	14	80	4	1.90
2	57	152	120.6	¾	18	99	4	3.01
2½	76.1	178	139.7	¾	18	120	4	4.68
3	88.9	190	152.4	¾	19	130	4	5.70
4	108	229	190.5	¾	24	158	8	8.67
6	159	279	241.3	7/8	27	212	8	15.46
8	219.1	343	298.4	7/8	31	270	8	24.90
10	267	406	362.0	1	38	320	12	41.23
12	323.9	483	431.8	1	41	370	12	70.55
14	368	533	476.2	1 1/8	45	430	12	93.16
16	419	597	539.8	1 1/8	51	482	16	123.99
18	457.2	635	577.8	1 ¼	52	530	16	147.55
20	508	698	635.0	1 ¼	58	585	20	191.00
24	610	813	749.3	1 3/8	71	685	20	285.74
28	711	927	864.0	1 3/8	81	800	28	434.66
32	813	1060	978.0	1 5/8	95	905	28	665.63
36	914	1168	1086.0	1 5/8	105	1000	32	886.43

**Capillary Brazing, Socket Weld Fittings  
and Miscellaneous**

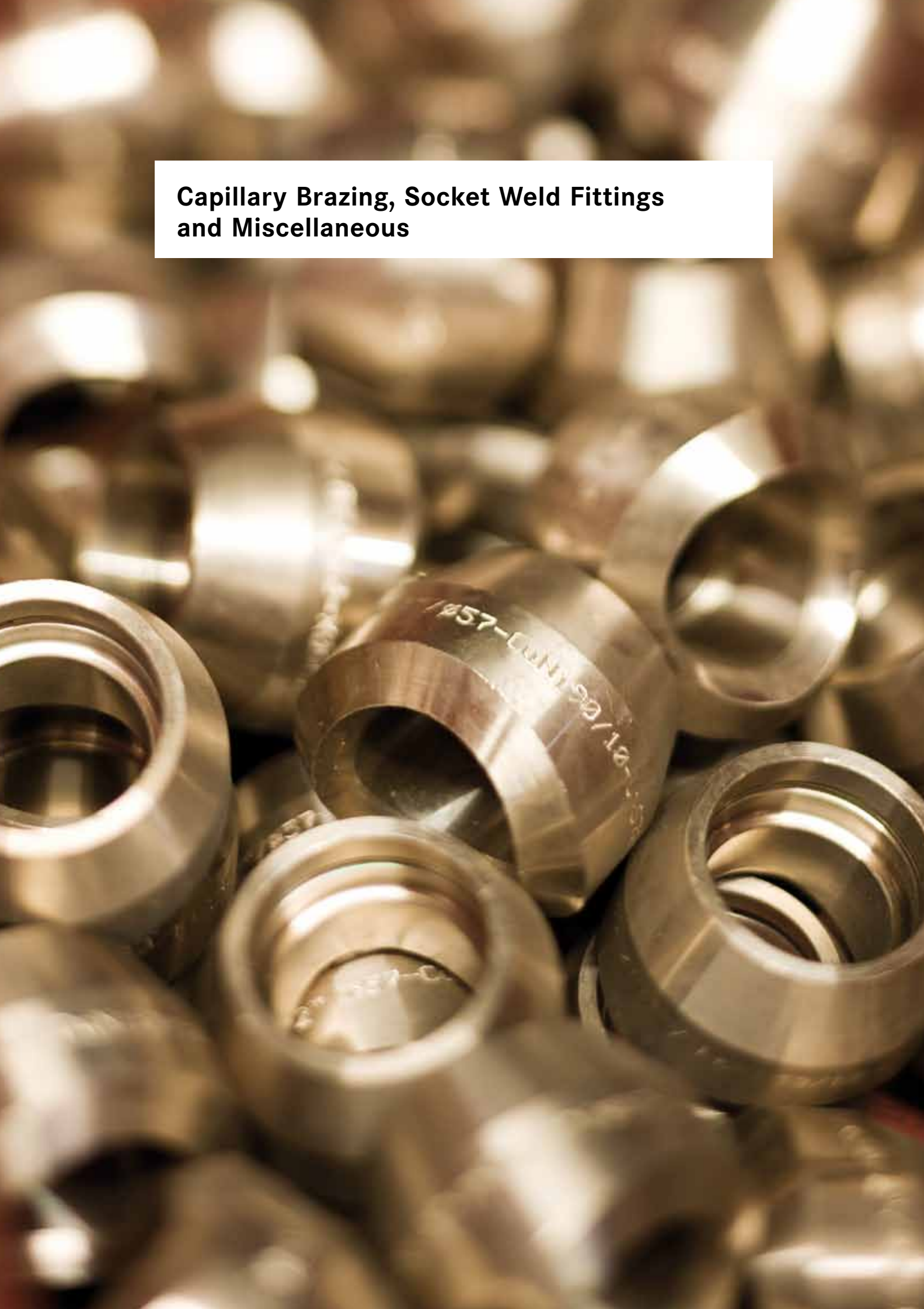

Material  
OSNA®-10 – CuNi 90/10

Capillary brazing end – CB  
Socket welding – SW

# Socket Welding Elbow 45°/90° Capillary Brazing Elbow 45°/90°

**Elbows 45°**  
16 mm – 57 mm  
CB or SW

**CB**

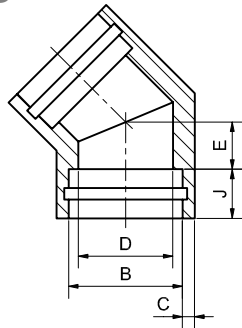

**SW**

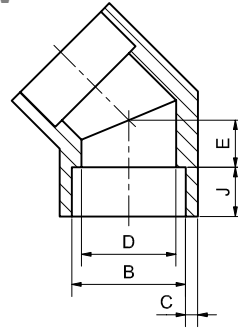

**Dimensions Table 45°**

nominal	specified	C		E	J	B		D	weight ~kg
		min mm	min mm	min mm	min mm	min/max mm	min mm		
1/2	16	3.2	9	10	16.070	16.121	12	0.080	
3/4	25	3.2	9.5	13	25.080	25.131	21	0.139	
1	30	3.2	12.5	13	30.080	30.131	25	0.201	
1 1/4	38	3.2	15.5	13	38.095	38.146	33	0.289	
1 1/2	44.5	3.2	20	13	44.595	44.646	39.5	0.402	
2	57	3.2	20	16	57.225	57.276	52	0.552	

**Elbows 90°**  
16 mm – 57 mm  
CB or SW

**CB**

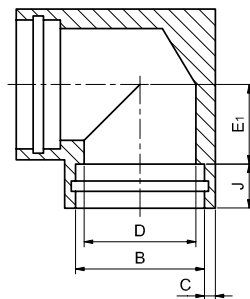

**SW**

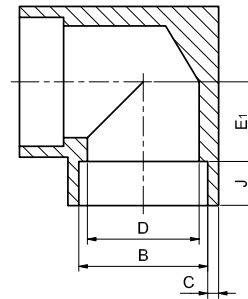

**Dimensions Table 90°**

nominal	specified	C	J	D	B		E1	weight ~kg
		min mm	min mm	min mm	min/max mm	min mm		
1/2	16	3.2	10	12	16.070	16.121	11	0.091
3/4	25	3.2	13	21	25.080	25.131	13	0.170
1	30	3.2	13	25	30.080	30.131	16.5	0.248
1 1/4	38	3.2	13	33	38.095	38.146	23.5	0.406
1 1/2	44.5	3.2	13	39.5	44.595	44.646	28	0.547
2	57	3.2	16	52	57.225	57.276	31.5	0.831

# Socket Welding Tees Capillary Brazing Tees

Material  
OSNA®-10 – CuNi 90/10

Capillary brazing end – CB  
Socket welding – SW

**Equal Tees**  
16 mm – 57 mm  
CB or SW

**CB**

**SW**

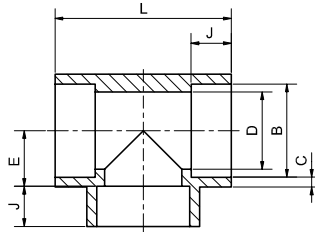
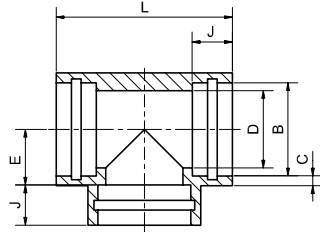

**Dimensions Table Equal Tees**

nominal specified		D		B		C	J	L	N	weight
inch	mm	min	max/min	min	max/min	min	min	min	min	~kg
		mm	mm	mm	mm	mm	mm	mm	mm	
½	<b>16</b>	12	16.121	16.070	3.2	10	42	11	0.107	
¾	<b>25</b>	21	25.131	25.080	3.2	13	52	13	0.193	
1	<b>30</b>	25	30.131	30.080	3.2	13	57	15.5	0.261	
1¼	<b>38</b>	33	38.146	38.095	3.2	13	73	23.5	0.428	
1½	<b>44.5</b>	39.5	44.646	44.595	3.2	13	82	28	0.567	
2	<b>57</b>	52	57.276	57.225	3.2	16	95	31.5	0.804	

**Reducing Tees**  
16 mm – 57 mm  
CB or SW

**CB**

**SW**

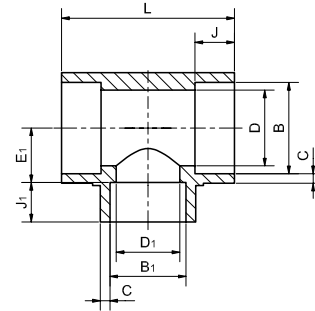
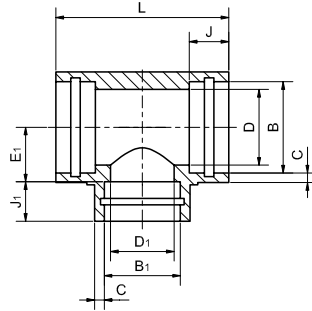

**Dimensions Table Reducing Tees**

nominal specified		D		B	J	C	D <sub>1</sub>		B <sub>1</sub>		J <sub>1</sub>	L	E <sub>1</sub>	weight
inch	mm	min	max/min	max/min	min	min	min	max/min	max/min	min	min	min	min	~kg
		mm	mm	mm	mm	mm	mm	mm	mm	mm	mm	mm	mm	
¾ x ½	<b>25 x 16</b>	21	25.131	25.080	13	3.2	12	16.121	16.070	10	52	16	0.196	
1 x ½	<b>30 x 16</b>	25	30.131	30.080	13	3.2	12	16.121	16.070	10	57	18.5	0.270	
1 x ¾	<b>30 x 25</b>	25	30.131	30.080	13	3.2	21	25.131	25.080	13	57	15.5	0.269	
1¼ x ½	<b>38 x 16</b>	33	38.146	38.095	13	3.2	12	16.121	16.070	10	73	26.5	0.481	
1¼ x ¾	<b>38 x 25</b>	33	38.146	38.095	13	3.2	21	25.131	25.080	13	73	23.5	0.454	
1¼ x 1	<b>38 x 30</b>	33	38.146	38.095	13	3.2	25	30.131	30.080	13	73	23.5	0.451	
1½ x ½	<b>44.5 x 16</b>	39.5	44.646	44.595	13	3.2	12	16.121	16.070	10	82	31	0.651	
1½ x ¾	<b>44.5 x 25</b>	39.5	44.646	44.595	13	3.2	21	25.131	25.080	13	82	28	0.629	
1½ x 1	<b>44.5 x 30</b>	39.5	44.646	44.595	13	3.2	25	30.131	30.080	13	82	28	0.623	
1½ x 1¼	<b>44.5 x 38</b>	39.5	44.646	44.595	13	3.2	33	38.146	38.095	13	82	28	0.600	
2 x ½	<b>57 x 16</b>	52	57.276	57.225	16	3.2	12	16.121	16.070	10	95	37.5	0.972	
2 x ¾	<b>57 x 25</b>	52	57.276	57.225	16	3.2	21	25.131	25.080	13	95	34.5	0.966	
2 x 1	<b>57 x 30</b>	52	57.276	57.225	16	3.2	25	30.131	30.080	13	95	34.5	0.961	
2 x 1¼	<b>57 x 38</b>	52	57.276	57.225	16	3.2	33	38.146	38.095	13	95	34.5	0.939	
2 x 1½	<b>57 x 44.5</b>	52	57.276	57.225	16	3.2	39.5	44.646	44.595	13	95	34.5	0.911	

# Socket Welding Couplings Capillary Brazing Couplings

Capillary brazing end – CB  
Socket welding – SW

**Equal Couplings**  
29 mm – 76 mm  
CB or SW

**CB**

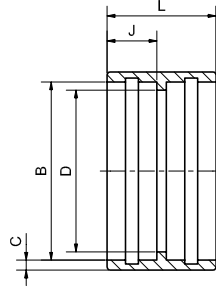

**SW**

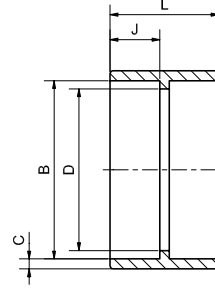

**Dimensions Table Equal Couplings**

nominal specified		D		B		C		J		L		weight
inch	mm	min	max/min	max/min	min	min	min	min	min	min	~kg	
		mm	mm	mm	mm	mm	mm	mm	mm	mm		
½	<b>16</b>	12	16.121	16.070	3.2	10	22	0.039				
¾	<b>25</b>	21	25.131	25.080	3.2	13	28	0.073				
1	<b>30</b>	25	30.131	30.080	3.2	13	28	0.087				
1¼	<b>38</b>	33	38.146	38.095	3.2	13	28	0.108				
1½	<b>44.5</b>	39.5	44.646	44.595	3.2	13	29	0.132				
2	<b>57</b>	52	57.276	57.225	3.2	16	35	0.201				

**Reducing Couplings**  
25 mm – 57 mm  
CB or SW

**CB**

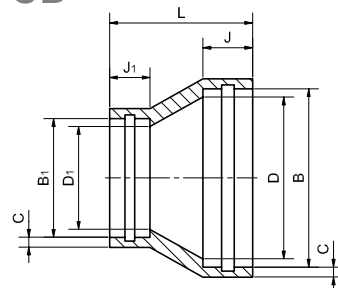

**SW**

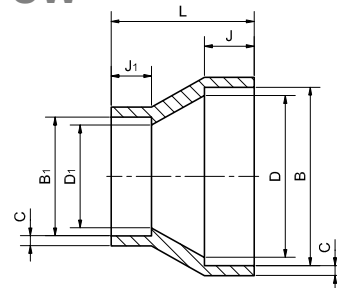

**Dimensions Table Reducing Couplings**

nominal specified		D		B		J		C		D <sub>1</sub>		B <sub>1</sub>		J <sub>1</sub>		L		weight
inch	mm	min	max/min	max/min	min	min	min	min	min	min	max/min	max/min	min	min	min	min	~kg	
		mm	mm	mm	mm	mm	mm	mm	mm	mm	mm	mm	mm	mm	mm	mm		
¾ x ½	<b>25 x 16</b>	21	25.131	25.080	13	3.2	12	16.121	16.070	10	36	0.092						
1 x ½	<b>30 x 16</b>	25	30.131	30.080	13	3.2	12	16.121	16.070	10	37	0.108						
1 x ¾	<b>30 x 25</b>	25	30.131	30.080	13	3.2	21	25.131	25.080	13	33	0.102						
1¼ x ½	<b>38 x 16</b>	33	38.146	38.095	13	3.2	12	16.121	16.070	10	43	0.152						
1¼ x ¾	<b>38 x 25</b>	33	38.146	38.095	13	3.2	21	25.131	25.080	13	37	0.136						
1¼ x 1	<b>38 x 30</b>	33	38.146	38.095	13	3.2	25	30.131	30.080	13	33	0.126						
1½ x ½	<b>44.5 x 16</b>	39.5	44.646	44.595	13	3.2	12	16.121	16.070	10	49	0.199						
1½ x ¾	<b>44.5 x 25</b>	39.5	44.646	44.595	13	3.2	21	25.131	25.080	13	43	0.182						
1½ x 1	<b>44.5 x 30</b>	39.5	44.646	44.595	13	3.2	25	30.131	30.080	13	39	0.174						
1½ x 1¼	<b>44.5 x 38</b>	39.5	44.646	44.595	13	3.2	33	38.146	38.095	13	32	0.144						
2 x ½	<b>57 x 16</b>	52	57.276	57.225	16	3.2	12	16.121	16.070	10	63	0.322						
2 x ¾	<b>57 x 25</b>	52	57.276	57.225	16	3.2	21	25.131	25.080	13	58	0.310						
2 x 1	<b>57 x 30</b>	52	57.276	57.225	16	3.2	25	30.131	30.080	13	53	0.298						
2 x 1¼	<b>57 x 38</b>	52	57.276	57.225	16	3.2	33	38.146	38.095	13	46	0.268						
2 x 1½	<b>57 x 44.5</b>	52	57.276	57.225	16	3.2	39.5	44.646	44.595	13	40	0.234						

# Capillary Brazing (Half)-Couplings Socket Welding (Half)-Couplings

Material  
OSNA®-10 – CuNi 90/10

Capillary brazing end – CB  
Socket welding – SW

(Half)-Couplings  
16 mm – 57 mm  
CB or SW

CB

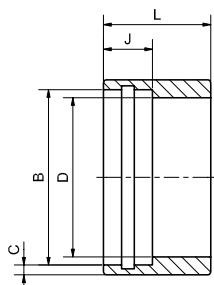

SW

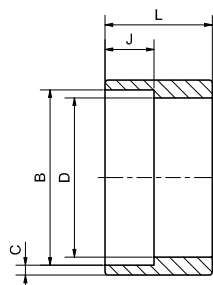

Dimensions Table Brazing (Half)-Couplings / Socket Welding (Half)-Couplings

nominal	specified	D		B		C	J	L	Halfcoupling	Coupling
		min	max/min	min	min	min	min	min	weight	weight
inch	mm	mm	mm	mm	mm	mm	mm	mm	~kg	~kg
1/2	16	12	16.121	16.070	3.2	10	22		0.047	0.039
3/4	25	21	25.131	25.080	3.2	13	28		0.090	0.073
1	30	25	30.131	30.080	3.2	13	28		0.112	0.087
1 1/4	38	33	38.146	38.095	3.2	13	28		0.141	0.108
1 1/2	44.5	39.5	44.646	44.595	3.2	13	29		0.171	0.132
2	57	52	57.276	57.225	3.2	16	35		0.266	0.201

Couplings NPT  
16 mm – 57 mm

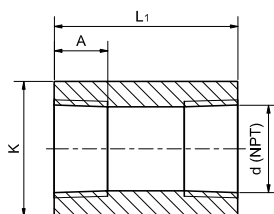

Dimensions Table Couplings NPT

nominal	OD	L <sub>1</sub>		A	weight
		min	min	min	~kg
inch	mm	mm	mm	mm	
1/2	29	48		13.5	0.188
3/4	35	51		14.0	0.263
1	44	60		17.5	0.490
1 1/4	57	67		18.0	0.902
1 1/2	64	79		18.5	1.273
2	76	86		19.0	1.701

**Welding Ends**  
16 mm – 57 mm

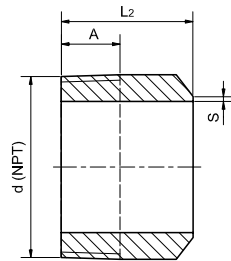

**Dimensions Table Welding Ends**

nominal		specified	d	Lz	A	S	Coupling
inch	mm		Thread	mm	min	mm	weight
			NPT		mm		~kg
1/2	21.3		1/2	24.0	13.6	1.6	0.049
3/4	26.7		3/4	25.5	13.9	1.6	0.076
1	33.4		1	30.0	17.3	1.6	0.131
1 1/4	42.2		1 1/4	33.5	18.0	1.6	0.196
1 1/2	48.3		1 1/2	39.5	18.4	1.6	0.298
2	60.3		2	43.0	19.2	1.6	0.488





# Straight Male Connector Straight Female Connector

**Capillary Brazing  
Connector 30**  
16 mm – 57 mm

**Female**

**Male**

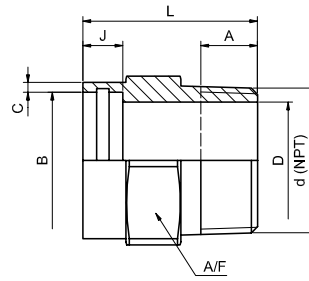
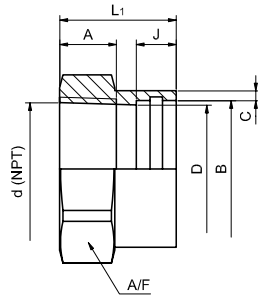

**Socket Welding  
Connector 30**  
16 mm – 57 mm

**Female**

**Male**

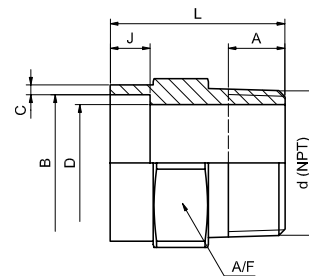
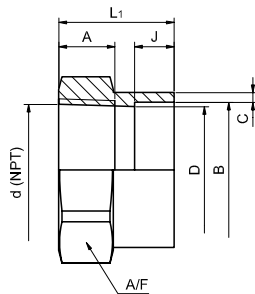

**Dimensions Table Female**

nominal		specified	d		B	C	L <sub>1</sub>	J	A	A/F	weight
inch	mm		Thread	max/min	max/min	min	mm	min	min	mm	~kg
			NPT	mm	mm	mm		mm	mm		
1/2	16		1/2	16.121 16.070	3.2	32	10	13.5	27	0.070	
3/4	25		3/4	25.131 25.080	3.2	33	13	14	32	0.110	
1	30		1	30.131 30.080	3.2	37	13	17.5	41	0.180	
1 1/4	38		1 1/4	38.146 38.095	3.2	38	13	18	50	0.240	
1 1/2	44.5		1 1/2	44.646 44.595	3.2	38	13	18.5	55	0.280	
2	57		2	57.276 57.225	3.2	42	16	19	70	0.470	

**Dimensions Table Male**

nominal		specified	A	B	C	D	L	J	A	A/F	weight
inch	mm		max/min	max/min	min	mm	mm	mm	mm	mm	~kg
			mm	mm	mm						
1/2	16		16.121 16.070	3.2	13.8	40	10	13.5	27	0.090	
3/4	25		25.131 25.080	3.2	18.9	46	13	14	32	0.150	
1	30		30.131 30.080	3.2	24.3	52	13	17.5	41	0.250	
1 1/4	38		38.146 38.095	3.2	32.5	54	13	18	50	0.350	
1 1/2	44.5		44.646 44.595	3.2	38.1	57	13	18.5	55	0.440	
2	57		57.276 57.225	3.2	49.2	63	16	19	70	0.720	

# Male Unions and Unions

Socket Welding Unions, Capillary Brazing Unions, Male Unions, Socket Welding x Male Thread, Capillary Brazing x Male Thread

Material  
OSNA®-10 – CuNi 90/10

Capillary brazing end – CB  
Socket welding – SW

**Male Unions**  
25 mm – 57 mm  
CB or SW

**CB**

**SW**

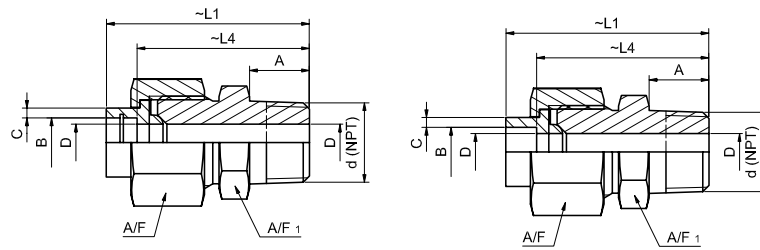

**Dimensions Table Male Unions**

nominal	specified	d	C	B		D	L <sub>1</sub>	L <sub>4</sub>	A	A/F	A/F <sub>1</sub>	weight
				Thread	min							
inch	mm	Thread	mm	mm	mm	mm	mm	mm	mm	mm	mm	~kg
1/2	16 x 3/4	3/4	3.2	16.121	16.070	12.0	66	56	14	36	32	0.39
3/4	25 x 1	1	3.2	25.131	25.080	21.0	81	68	17.5	46	41	0.69
1	30 x 1 1/4	1 1/4	3.2	30.131	30.080	25.0	83.5	70.5	18	50	46	0.87
1 1/4	38 x 1 1/2	1 1/2	3.2	38.146	38.095	33.0	86.5	73.5	18.5	60	55	1.17
1 1/2	44.5 x 1 1/2	1 1/2	3.2	44.646	44.595	39.5	91.5	78.5	18.5	70	60	1.46
2	57 x 2	2	3.2	57.276	57.225	52.0	100.5	84.5	19	85	75	2.18

**Unions**  
25 mm – 57 mm  
CB or SW

**CB**

**SW**

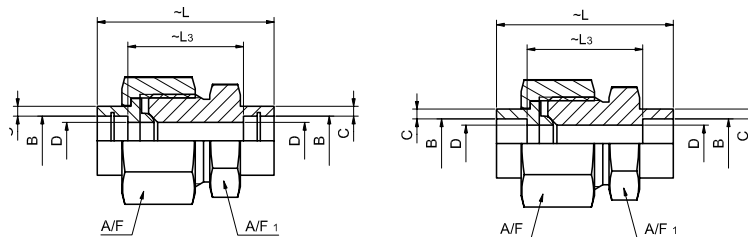

**Dimensions Table Unions**

nominal	specified	C	B		D	L	L <sub>3</sub>	A/F	A/F <sub>1</sub>	weight
			min	max/min						
inch	mm	mm	mm	mm	mm	mm	mm	mm	mm	~kg
1/2	16	3.2	16.121	16.070	12.0	58	38	36	32	0.34
3/4	25	3.2	25.131	25.080	21.0	71	45	46	41	0.62
1	30	3.2	30.131	30.080	25.0	72.5	46.5	50	46	0.71
1 1/4	38	3.2	38.146	38.095	33.0	75.5	49.5	60	55	1.02
1 1/2	44.5	3.2	44.646	44.595	39.5	80.5	54.5	70	60	1.39
2	57	3.2	57.276	57.225	52.0	91.5	59.5	85	75	2.12

**Hex. Head and  
Flush Bushings**  
16 mm – 57 mm

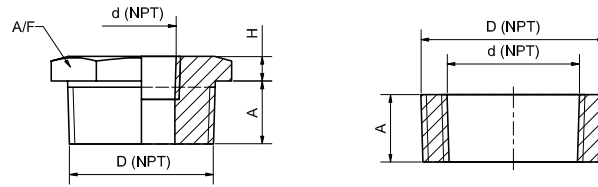

**Dimensions Table**

nominal size	Thread D	Thread d	A min	H	A/F	Hex. Head weight	Flush weight
1/2	1/2	1/4	14.5	5	22	0.048	0.033
3/4	3/4	1/4	16.0	6	27	0.094	0.065
3/4	3/4	3/8	16.0	6	27	0.082	0.056
1	1	1/4	19.0	6	35	0.181	0.129
1	1	3/8	19.0	6	35	0.167	0.118
1	1	1/2	19.0	6	35	0.150	0.105
1 1/4	1 1/4	1/4	20.5	7	44.5	0.333	0.233
1 1/4	1 1/4	3/8	20.5	7	44.5	0.318	0.221
1 1/4	1 1/4	1/2	20.5	7	44.5	0.299	0.207
1 1/4	1 1/4	3/4	20.5	7	44.5	0.260	0.177
1 1/2	1 1/2	1/4	20.5	8	51	0.463	0.311
1 1/2	1 1/2	3/8	20.5	8	51	0.447	0.299
1 1/2	1 1/2	1/2	20.5	8	51	0.428	0.285
1 1/2	1 1/2	3/4	20.5	8	51	0.387	0.255
1 1/2	1 1/2	1	20.5	8	51	0.331	0.214
2	2	1/4	22.0	9	63.5	0.799	0.530
2	2	3/8	22.0	9	63.5	0.782	0.518
2	2	1/2	22.0	9	63.5	0.761	0.503
2	2	3/4	22.0	9	63.5	0.716	0.471
2	2	1	22.0	9	63.5	0.655	0.427
2	2	1 1/4	22.0	9	63.5	0.534	0.341
2	2	1 1/2	22.0	9	63.5	0.432	0.268

# Sprinkler Bushing

Material  
OSNA®-10 – CuNi 90/10

## Sprinkler Bushing 25 mm – 57 mm

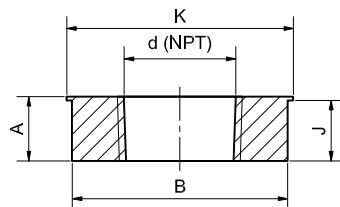

### Dimensions Table

nominal		specified		B		A	J	K	d	weight
inch	mm	max/min		min	min	mm	mm	mm	Thread	~kg
		mm	mm	mm	mm				NPT	
3/4	<b>25</b>	25.031	24.980	14	13	28	1/2	0.031		
<b>1</b>	<b>30</b>	30.055	29.975	14	13	33	1/2	0.058		
1 1/4	<b>38</b>	38.070	37.990	14	13	41	1/2	0.112		
1 1/2	<b>44.5</b>	44.570	44.490	14	13	47.5	1/2	0.165		
<b>2</b>	<b>57</b>	57.200	57.120	17	16	60	1/2	0.350		
<b>1</b>	<b>30</b>	30.055	29.975	14	13	33	3/4	0.037		
1 1/4	<b>38</b>	38.070	37.990	14	13	41	3/4	0.091		
1 1/2	<b>44.5</b>	44.570	44.490	14	13	47.5	3/4	0.143		
<b>2</b>	<b>57</b>	57.200	57.120	17	16	60	3/4	0.324		
1 1/4	<b>38</b>	38.070	37.990	14	13	41	1	0.061		
1 1/2	<b>44.5</b>	44.570	44.490	14	13	47.5	1	0.114		
<b>2</b>	<b>57</b>	57.200	57.120	17	16	60	1	0.288		
1 1/2	<b>44.5</b>	44.570	44.490	14	13	47.5	1 1/4	0.057		
<b>2</b>	<b>57</b>	57.200	57.120	17	16	60	1 1/4	0.219		
<b>2</b>	<b>57</b>	57.200	57.120	17	16	60	1 1/2	0.161		

**Threadolets**  
16 mm – 57 mm

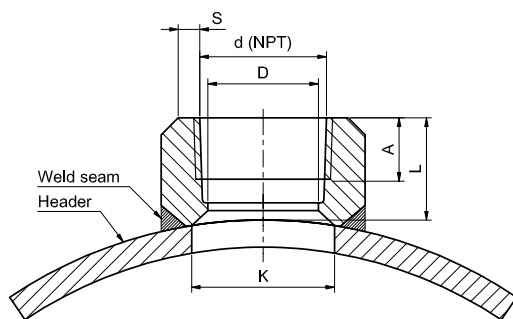

**Dimensions Table Threadolets** 16/1/2" - 965/38" x 16/1/2" - 57/2" - 16/20 bar

Nominal Branch Size	Header Size Ranges	L Nom	D Nom	K Nom	A min	S
d NPT inch	mm	mm	mm	mm	mm	mm
1/2	16 - 965	24	13.84	14.0 - 21.0	13.5	4.78
3/4	25 - 965	24	18.88	21.0 - 26.0	14.0	5.56
1	30 - 965	28	24.30	26.8 - 33.0	17.5	6.35
1 1/4	38 - 965	30	32.50	34.8 - 42.0	18.0	6.35
1 1/2	44.5 - 965	33 - 34	38.14	53.8 - 59.5	18.5	7.14
2	57 - 965	34 - 38	49.22	53.8 - 59.5	19.0	8.74

# Sockolets

Material  
OSNA®-10 – CuNi 90/10

**Sockolets**  
16 mm – 57 mm

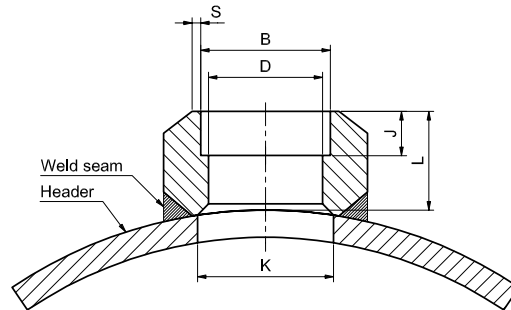

**Dimensions Table Sockolets** 16/1/2" - 965/38" x 16/1/2" - 57/2" - 16/20 bar

Branch	Header Size	L		D		K		J		B		S	
		Nom	max/min	Nom	max/min	Nom	max/min	Nom	max/min	min/max	min/max	min/max	min/max
Specified OD	Ranges	mm	mm	mm	mm	mm	mm	mm	mm	mm	mm	mm	mm
<b>16</b>	<b>16 - 965</b>	18	11.565 - 12.445	12.8	- 17	10	16.070 - 16.121	1.8	- 2				
<b>25</b>	<b>25 - 965</b>	23	20.575 - 21.445	26	- 26	13	25.080 - 25.131	1.8	- 2				
<b>30</b>	<b>30 - 965</b>	26	24.475 - 25.555	31	- 31	13	30.080 - 30.131	2.25	- 2.5				
<b>38</b>	<b>38 - 965</b>	29	32.490 - 33.570	34.8	- 40	13	32.490 - 33.570	2.25	- 2.5				
<b>44.5</b>	<b>44.5 - 965</b>	32	38.990 - 40.070	41.3	- 45	13	38.990 - 40.070	2.25	- 2.5				
<b>57</b>	<b>57 - 965</b>	36	51.620 - 52.700	53.8	- 58	16	57.225 - 57.276	2.25	- 2.5				

Material  
OSNA®-10 – CuNi 90/10

Capillary brazing end – CB  
Socket welding – SW

# Socket Welding End Caps Capillary Brazing End Caps NPT End Caps

**End Caps**  
16 mm – 57 mm  
CB or SW

**CB**

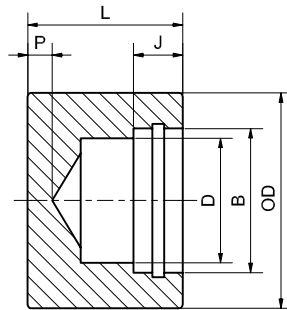

**SW**

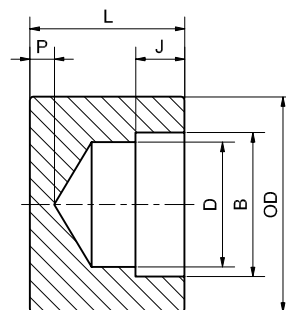

**NPT End Caps**  
16 mm – 57 mm

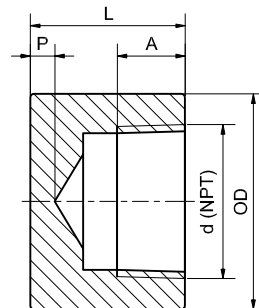

## Dimensions Table

nominal		specified		OD		B		D	L	P	J	A	d	weight
inch	mm	min	max/min	min	min	min	min	min	min	min	min	min	NPT	~kg
1/2	16	29	16.121 16.070	12	32	6.5	10	13.5	1/2	0.149				
3/4	25	35	25.131 25.080	21	37	6.5	13	14.0	3/4	0.216				
1	30	44	30.131 30.080	25	38	6.5	13	17.5	1	0.363				
1 1/4	38	57	38.146 38.095	33	41	6.5	13	18.0	1 1/4	0.665				
1 1/2	44.5	64	44.646 44.595	39.5	41	6.5	13	18.5	1 1/2	0.814				
2	57	76	57.276 57.225	52	42	6.5	16	19.0	2	1.098				



# Barrel Nipples/Male Nipple both

Material  
OSNA®-10 – CuNi 90/10

**Barrel Nipple**  
21,3 mm – 60,3 mm

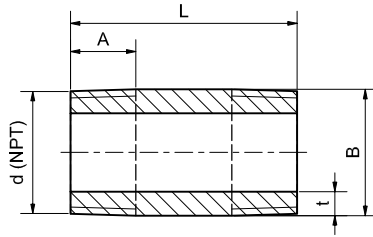

**Dimensions Table Barrel Nipples**

nominal	B specified	d	L	A	t	weight
inch	mm	NPT	mm	mm	mm	
1/2	21.3	1/2	48	13.6	4.78	0.103
3/4	26.7	3/4	51	13.9	5.56	0.163
1	33.4	1	60	17.3	6.35	0.280
1 1/4	42.2	1 1/4	67	18.0	6.35	0.415
1 1/2	48.3	1 1/2	79	18.4	7.14	0.635
2	60.3	2	86	19.2	8.74	1.064

**Male Nipple both**  
21,3 mm – 60,3 mm

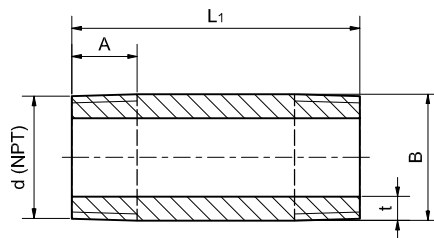

**Dimensions Table Male Nipple both**

nominal	B specified	d	L1	A	t	weight
inch	mm	NPT	mm	mm	mm	
1/2	21.3	1/2	76.2	13.6	4.78	0.165
3/4	26.7	3/4	76.2	13.9	5.56	0.246
1	33.4	1	76.2	17.3	6.35	0.357
1 1/4	42.2	1 1/4	76.2	18.0	6.35	0.473
1 1/2	48.3	1 1/2	76.2	18.4	7.14	0.612
2	60.3	2	76.2	19.2	8.74	0.941
1/2	21.3	1/2	101.6	13.6	4.78	0.221
3/4	26.7	3/4	101.6	13.9	5.56	0.329
1	33.4	1	101.6	17.3	6.35	0.479
1 1/4	42.2	1 1/4	101.6	18.0	6.35	0.635
1 1/2	48.3	1 1/2	101.6	18.4	7.14	0.821
2	60.3	2	101.6	19.2	8.74	1.261

**Male Nipple one**  
21,3 mm – 60,3 mm

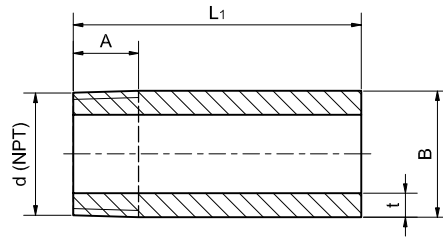

**Dimensions Table Male Nipple one**

nominal inch	B specified mm	d Thread NPT	L <sub>1</sub> min mm	A min mm	t mm	weight ~kg
1/2	21.3	1/2	76.2	13.6	4.78	0.167
3/4	26.7	3/4	76.2	13.9	5.56	0.248
1	33.4	1	76.2	17.3	6.35	0.362
1 1/4	42.2	1 1/4	76.2	18.0	6.35	0.479
1 1/2	48.3	1 1/2	76.2	18.4	7.14	0.619
2	60.3	2	76.2	19.2	8.74	0.950
1/2	21.3	1/2	101.6	13.6	4.78	0.223
3/4	26.7	3/4	101.6	13.9	5.56	0.332
1	33.4	1	101.6	17.3	6.35	0.484
1 1/4	42.2	1 1/4	101.6	18.0	6.35	0.641
1 1/2	48.3	1 1/2	101.6	18.4	7.14	0.828
2	60.3	2	101.6	19.2	8.74	1.270

# Female/Male Adaptor

Material  
OSNA®-10 – CuNi 90/10

## Female End Adapter 16 mm – 57 mm

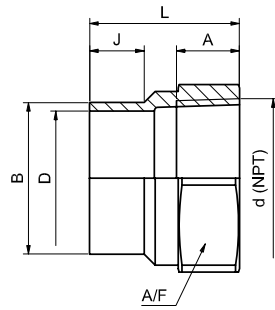

Dimensions Table Female Adaptor

nominal	specified	d	B	D	L	J	A	A/F	weight
inch	mm	Thread NPT	max/min mm	min mm	min mm	min mm	min mm	mm	~kg
1/2	16	1/2	16.045 15.965	12	36	13	13.5	27	0.070
3/4	25	3/4	25.055 24.975	21	39	16	14	32	0.110
1	30	1	30.055 29.975	25	43	16	17.5	41	0.190
1 1/4	38	1 1/4	38.070 37.990	33	44	16	18	50	0.240
1 1/2	44.5	1 1/2	44.570 44.490	39.5	44	16	18.5	55	0.290
2	57	2	57.200 57.120	52	48	19	19	70	0.470

## Male End Adapter 16 mm – 57 mm

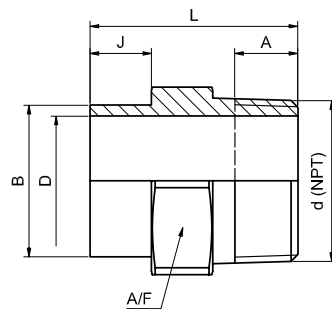

Dimensions Table Male Adaptor

nominal	specified	d	B	D	L	J	A	A/F	weight
inch	mm	Thread NPT	max/min mm	min mm	min mm	min mm	min mm	mm	~kg
1/2	16	1/2	16.045 15.965	12.0	44	15	13.5	27	0.100
3/4	25	3/4	25.055 24.975	18.9	50	18	14	32	0.140
1	30	1	30.055 29.975	24.3	56	18	17.5	41	0.240
1 1/4	38	1 1/4	38.070 37.990	32.5	58	18	18	50	0.340
1 1/2	44.5	1 1/2	44.570 44.490	38.1	61	18	18.5	55	0.440
2	57	2	57.200 57.120	49.2	67	21	19	70	0.740

# Hex., Round and Square Head Plugs

**Hex. Plug**  
21,3 mm – 60,3 mm

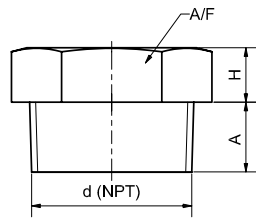

**Round Plug**  
21,3 mm – 60,3 mm

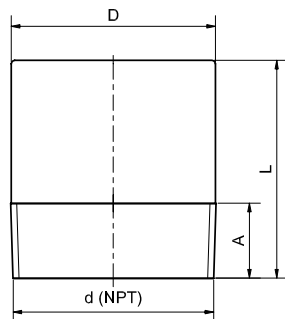

**Square Plug**  
21,3 mm – 60,3 mm

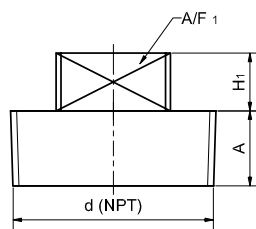

**Dimensions Table**

nominal size= Thread d	Length A	Width of flats A/F	Width of flats A/F <sub>1</sub>	Hex height H	Height of square H <sub>1</sub>	Lenght L	Dia of Head D	Hex. Head weight	Round Head weight	Square Head weight
NPT inch	min mm	min mm	min mm	min mm	min mm	min mm	min mm	~kg	~kg	~kg
1/2	14.5	22	14.5	8	10	44	21	0.074	0.135	0.063
3/4	16.0	27	16.0	10	11	44	27	0.133	0.219	0.102
1	19.0	36	20.5	10	13	51	33	0.242	0.386	0.191
1 1/4	20.5	44.5	24.0	14	14	51	43	0.461	0.641	0.319
1 1/2	20.5	51	28.5	16	16	51	48	0.645	0.616	0.441
2	22.0	63.5	33.5	17	17	64	60	1.073	1.603	0.716

# Figure 8 Blanks, Paddle Blanks, Paddle Spacer

Material  
OSNA®-10 – CuNi 90/10

Figure 8 Blank

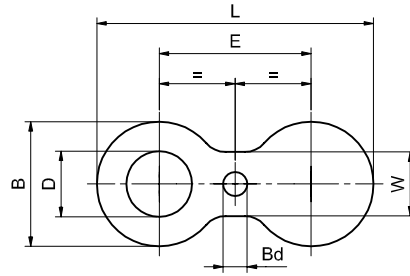

Paddle Blank

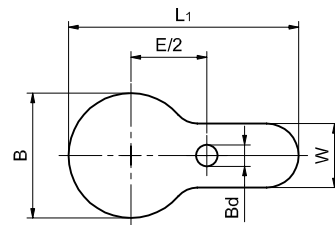

Paddle Spacer

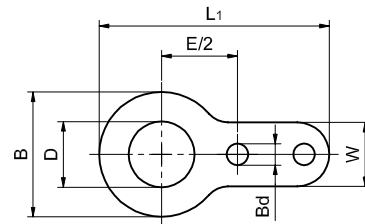

Dimensions Table

nominal dimension	outside diameter B	D	E	L	L <sub>1</sub>	W	t	Bd	Figure 8 Blanks weight	Paddle Spacer weight	Paddle Blanks weight
inch	mm	mm	mm	mm	mm	mm	mm	mm	~kg	~kg	~kg
1/2	40	12,00	60,3	100,3	110,4	38,10	4,6	16,0	0,133	0,139	0,144
3/4	50	21,00	69,8	119,8	119,9	38,10	4,6	16,0	0,177	0,156	0,170
1	60	25,00	79,4	139,4	129,9	38,10	4,6	16,0	0,240	0,185	0,205
1 1/4	70	33,03	88,9	158,9	139,4	38,10	7,9	16,0	0,529	0,363	0,423
1 1/2	80	39,53	98,4	178,4	149,4	38,10	7,9	16,0	0,666	0,419	0,505
2	99	52,16	120,6	219,6	184,5	50,80	7,9	19,0	1,006	0,645	0,795
2 1/2	120	71,23	139,7	259,7	208,0	50,80	7,9	19,0	1,375	0,777	1,056
3	130	84,08	152,4	282,4	219,0	63,50	7,9	19,0	1,579	0,881	1,270
4	158	102,13	190,5	348,5	252,5	63,50	11,2	19,0	3,308	1,651	2,466
6	212	152,38	241,3	453,3	317,7	76,20	14,2	22,2	6,921	3,032	5,341
8	270	210,10	298,4	568,4	378,7	76,20	14,2	22,2	10,365	3,758	8,146
10	320	255,93	362,0	682,0	448,4	101,60	17,3	25,4	17,524	6,198	14,106
12	370	309,74	431,8	801,8	511,9	101,60	20,6	25,4	26,782	8,215	22,013
14	430	351,00	476,2	906,2	580,1	107,95	20,6	28,6	36,414	11,453	29,171
16	482	399,84	539,8	1021,8	638,1	107,95	23,9	28,6	52,230	15,221	41,903
18	530	438,50	577,8	1107,8	684,3	114,30	26,9	31,8	70,871	20,292	56,479
20	585	486,50	635,0	1220,0	743,3	120,65	30,9	31,8	98,284	27,314	78,371
24	685	584,50	749,3	1434,3	863,9	139,70	34,2	34,9	145,382	37,059	118,643

*Material*  
OSNA®-10 - CuNi 90/10



# Appendix A

## Pressure/temperature ratings of flanges

Type of Flange	Size Range	Maximum Allowable Working Pressure-bar							
		16 bar system				20 bar system			
		38°C	50°C	75°C	100°C	38°C	50°C	75°C	100°C
Composite weld neck (section 1)	½ in/16 mm to 4 in/108 mm	see 20 bar system				20	19.7	18.6	17.3
	6 in/159 mm to 36 in/914 mm	16.0	16.0	16.0	15.7	20	19.7	18.6	17.3
Composite slip-on (section 2)	½ in/16 mm to 4 in/108 mm	see 20 bar system				20	19.7	18.6	17.3
Solid weld neck (section 3)	½ in/16 mm to 4 in/108 mm	see 20 bar system				20	19.7	18.6	17.3
	6 in/159 mm to 36 in/914 mm	16.0	16.0	16.0	15.7	20	19.7	18.6	17.3
Solid slip-on (section 4)	½ in/16 mm to 4 in/108 mm	see 20 bar system				20	19.7	18.6	17.3

## Surface finish of the copper-nickel stub end and flangejoint faces

Method of machining	Ra* µm		Rz* µm	
	min.	max.	min.	max.
	turning	3.2	12.5	12.5

### Note

The term "turning" includes any method of machining producing concentric or spiral grooves.

## Pressure/temperature ratings - fittings

Type of Fitting	Size Range	Maximum Allowable Working Pressure-bar							
		16 bar rating				20 bar rating			
		38°C	50°C	75°C	100°C	38°C	50°C	75°C	100°C
Butt welding fittings	1 in/30 mm to 4 in/108 mm	use 20 bar				20	19.7	18.6	17.3
	6 in/159 mm to 36 in/914 mm	16.0	16.0	16.0	15.7	20	19.7	18.6	17.3
Socket weld fittings	½ in/16 mm to 2 in/57 mm	use 20 bar				20	19.7	18.6	17.3
Capillary brazed fittings	½ in/16 mm to 2 in/57 mm	use 20 bar				20	19.7	18.6	17.3

## Mechanical Properties

	Tensile Strength				0.2 % Proof Stress		Elongation	Hardness
	N/mm <sup>2</sup>		PSI		N/mm <sup>2</sup>	PSI	% min	HV5
	min.	max.	min.	max.			on L = 5.65 √S <sub>0</sub>	max
Seamless Pipes	300	380	43.512	55.115	105	15.229	30	
Seam-welded pipes	280	-	40.611	-	105	15.229	30	120*
Weld neck and slip-on stub ends, solid weld neck and slip-on flanges	280	-			105	15.229	30	120*
Fittings	280	-	40.611		105	15.229	30	120*

\* Determined on finished tube outside of heat affected zone

# Appendix B

Temperature Range	SI Units	US Costomary Units	20°C	68°C	100°C	212°C	200°C	392°C	300°C	572°C	400°C	752°F
<b>Thermal Expansion Coefficient</b>	10-16/°K	10-16/°K			16.4	9.1	16.8	9.3	17.1	9.5	17.5	9.7
<b>Young's Modulus</b>	kN/mm <sup>2</sup>	ksi	124	18.000	118	17.110	112	16.240	106	15.370	100	14.500
<b>Modulus of Rigidity</b>	kN/mm <sup>2</sup>	ksi	50	6.800								
<b>Poisson's Ratio</b>	-	-	0.35		0.36		0.36		0.36			
<b>Density</b>	g/cm <sup>3</sup>	pound/inch <sup>3</sup>	8.91	0.321								
<b>Thermal Conductivity</b>	W/m°K	Btu/pound °F	51.7	29.9	60.2	34.8	70	40,5	78.9	45.6	86.7	50.1
<b>Specific Heat Capacity</b>	kJ/kg°K	BTU/pound °F	0.377	0.09								
<b>Electrical Conductivity</b>	MegaSiemens/cm	%IACS	0.053	9								
<b>Electrical Resistivity</b>	microhm-cm	circular mil ohm/foot	19.12	115.0								

# Appendix C

## Adjust the description of dimensions to the images

Size	90 deg & 45 deg elbows & tees (see tables 1.4, 1.6 & 1.7)	reducer (see table 1.9)	end caps (see table 1.8)
<b>Specified OD</b>	centre-to-end dimension D, E, C & M	overall lenght H	overall lenght h1 + h2
<b>up to and including 267</b>	± 2	± 2	+0.015 D <sub>0</sub> -0
<b>323.9 up to and including 711</b>	± 3	± 3	
<b>813 up to and including 914</b>	± 5	± 5	